



GETRA[®]

Bakery & Noodle Equipment

Planetary Mixer

GETRA

bali
coolers
www.balicoolers.com

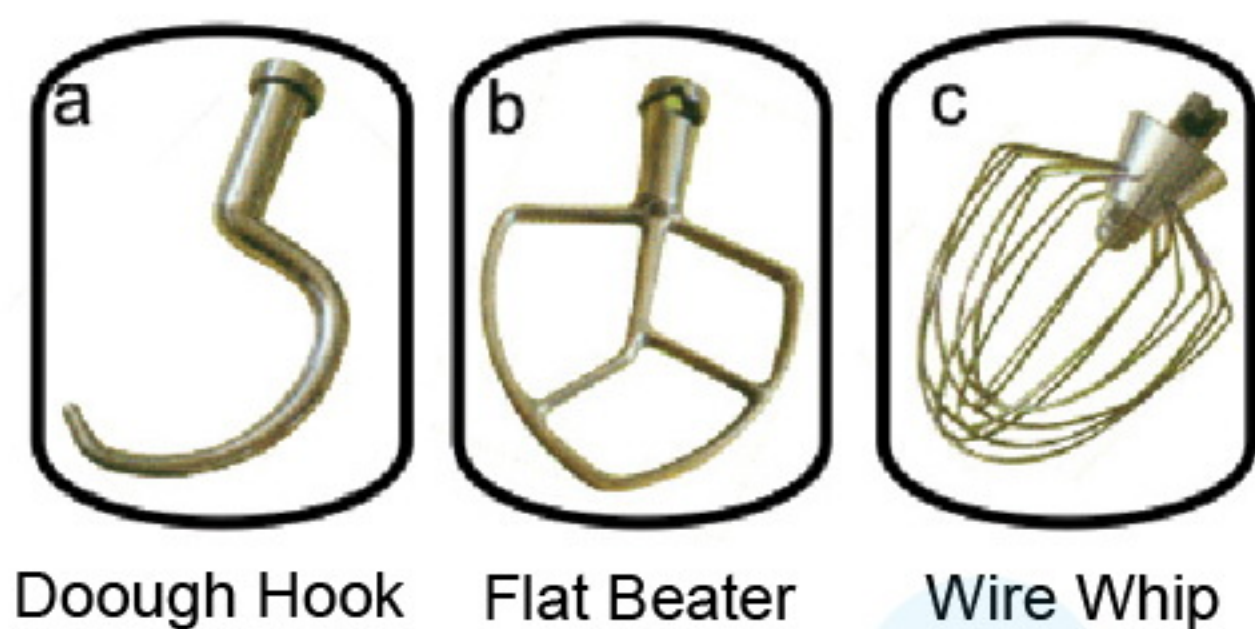

Dough Hook Flat Beater Wire Whip

Aplikasi 3 Jenis Pengaduk (Whisk)

- Mengaduk adonan roti yang sifatnya cenderung lengket agar lembut & kalis
- Mengaduk adonan kue, mentega, keju, kentang agar lebih merata
- Untuk mengocok telur & mentega, whipped cream, mengaduk adonan cair untuk saus, pancake susu



B-8

B-8

- Adjustable speed (130 ~ 900 rpm)
- Sturdy holder
- ON-OFF knob



B-10HJ



B-15HJ



B-20HJ



B-30HJ



B-40



B-60

B-10HJ ~ B-100

- Gear Driven



B-100

Note: Khusus u/ adonan kental dengan pengaduk spiral, posisi kecepatan harus di angka 1

TYPE	DIMENSION (cm)			BOWL VOLUME (L)	CAPACITY (kg)		WATT	VOLTAGE	MIXING SPEED (r/min)	WEIGHT(kg) Nett Gross
	L	W	H		Flour	Dough				
B-8	47	25,5	46,5	7,5	-	1	132~550		130~900	30 / 31
B-10HJ	50	37	67	10	2	3	370		67/189/362	50 / 60
B-15HJ	52	41	70	15	2,5	3,8	550	220V/1P/50Hz	67/189/362	55 / 67
B-20HJ	55	44	78	20	4	6	750		113/168/386	72 / 87
B-30HJ	58	45	82	26	6	9	1100		113/168/386	130 / 145
B-40	68	54	115	40	8	12	1800		65/102/296	210 / 225
B-60	102	63	145	60	16	24	2800	380/3P/50Hz	73/109/143/216	490 / 550
B-100	120,8	84	162,3	100	30	45	3000/4000	380/3P/50Hz	90/136/180/272	551 / 607

Planetary Mixer

GETRA[®]

bali
coolers
www.balicoolers.com



Seri Planetary Mixer mesin pencampur adonan menghasilkan adonan yang rata dan lembut. Bisa digunakan untuk mengaduk aneka macam adonan tepung, cairan dll. Kecepatan bisa diatur tergantung jenis bahan yang akan diaduk.

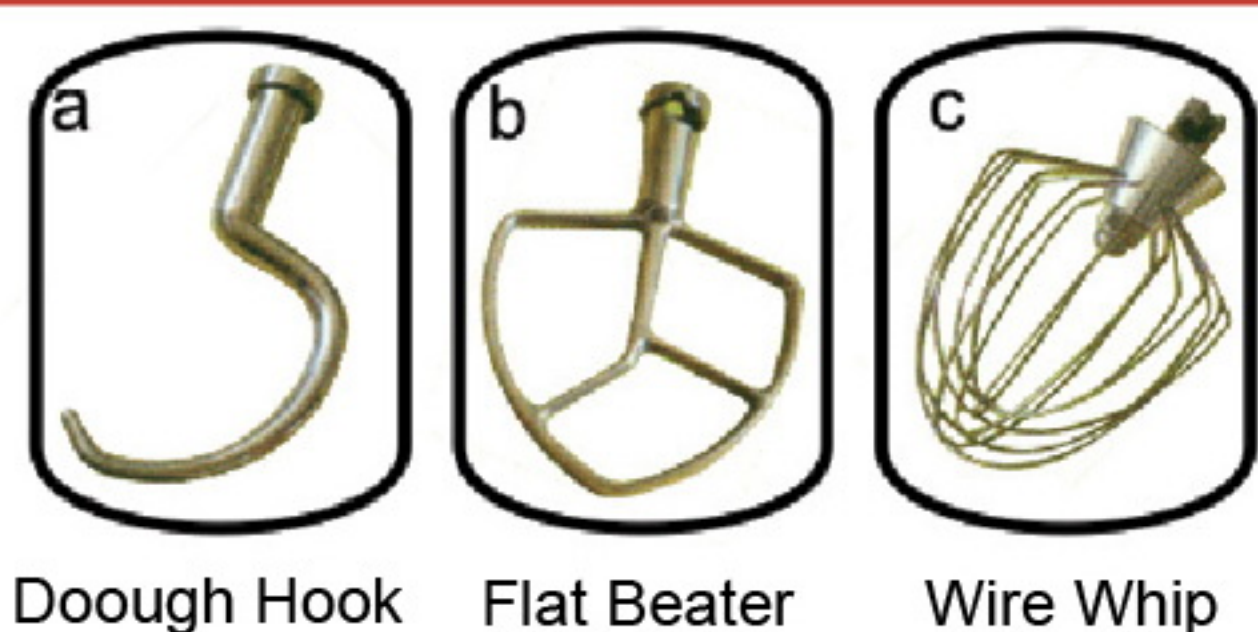

Dough Hook Flat Beater Wire Whip

Aplikasi 3 Jenis Pengaduk (Whisk)

- Mengaduk adonan roti yang sifatnya cenderung lengket agar lembut & kalis
- Mengaduk adonan kue, mentega, keju, kentang agar lebih merata
- Untuk mengocok telur & mentega, whipped cream, mengaduk adonan cair untuk saus, pancake susu

Belt Driven



Features

- With motor overload protection
- Adjustable speed 85/156/378 rpm
- Handle for up-down bowl
- Switch ON/OFF button
- Include 3 Whisk: dough hook, flat beater, wire whip

APN10C

APN20C

APN30C

TYPE	DIMENSION (cm)			BOWL VOLUME	CAPACITY (kg)		WATT	VOLTAGE	SPEED (r/min)	WEIGHT (kg) Nett Gross
	L	W	H		Flour	Dough				
APN10C	45	43,2	80,2	10 L	1,5	2	250	220V/1P/50Hz	85/156/378	65 / 78
APN20C	50	52,5	99,1	20 L	3	4,5	750	220V/1P/50Hz	85/156/378	77 / 93
APN30C	66	51	100	30 L	4	6	1100	220V/1P/50Hz	85/156/378	87 / 103

Gear Driven



BH15C

BH20C

BH30C

Features

- Transmission : gear driven
- Single phase (220V/1P/50Hz)
- With emergency stop button
- With overload motor protector
- S/s bowl
- Body color : black glossy

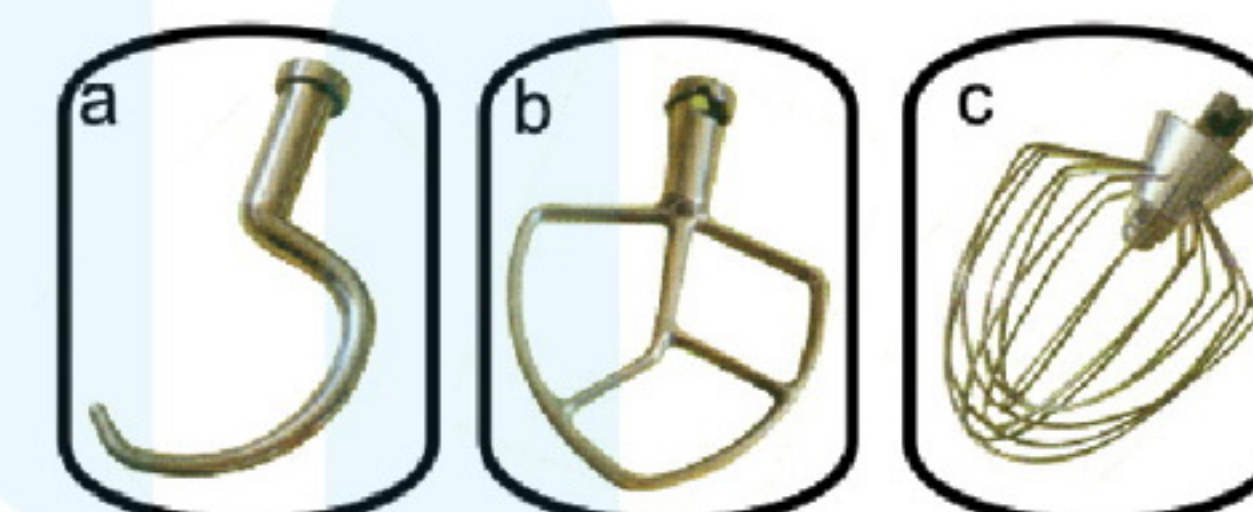

Dough Hook Flat Beater Wire Whip

TYPE	DIMENSION (cm)			BOWL VOLUME (L)	CAPACITY (kg)		WATT (220V/1P/50Hz)	MIXING SPEED (r/min)	WEIGHT (kg) NW/GW
	L	W	H		Flour	Dough			
BH10C	45	36,6	60,6	10	2	2,5	450	110/178/390	48 / 57
BH15C	45	36,6	60,6	15	2,5	3,3	450	110/178/390	48 / 58
BH20C	52	42	76	20	4	5,5	750	105/180/408	62 / 75
BH30C	54,5	44	88,2	30	6	8,5	1100	105/180/408	68 / 83

Spiral Mixer

GETRA[®]

bali
coolers
www.balicoolers.com



Spiral Mixer untuk membuat adonan roti kapasitas besar dengan putaran ganda (hook dan bowl)



DH-10



DH-20/A

Khusus type :
DH-20/A, DH-30/A & DH-50/A



DH-30/A



DH-50/A

Features

- 2 levels of rotational speed for DH-20 ~ DH-200
- Equipped with a safety guard + auto switch
- Stronger and quality motor
- Bowl rotation in the opposite direction to the hook

TYPE	DIMENSION (cm)			BOWL VOLUME (L)	CAPACITY (kg)		WATT	BOWL SPEED (r/min)	MIXING SPEED (r/min)	WEIGHT (kg) Nett Gross
	L	W	H		Flour	Dough				
DH-10	61,5	31,5	63	10	4	6	650/220V	15	160	62 / 67
DH-20/A	67,5	42,7	85,3	20	8	12	1100/220V	20/10	240/110	95 / 115
DH-30/A	72,5	43,2	88,6	30	12	18	1500/220V	20/10	240/110	99 / 120
DH-50/A	80	53,2	105,2	50	20	30	1500/2400/380V	30/15	240/120	140 / 169

Note: Untuk mendapatkan hasil yang lebih baik, sebaiknya memakai air dingin (air es)

Spiral Mixer

GETRA

bali
coolers
www.balicoolers.com



Spiral Mixer ini dirancang untuk kebutuhan pengadukan adonan roti dalam kapasitas besar dengan hasil yang efisien dan merata. Dilengkapi dengan sistem putaran ganda— s/s hook (pengaduk) dan s/s bowl (mangkuk)—mesin ini mampu menghasilkan adonan berkualitas tinggi, cocok untuk industri roti dan bakery.



Control panel



YQ-SF80, YQ-SF100

YQ-SF130, YQ-SF160

Features

- Control panel (Timer, indicator lamp, emergency stop)
- Double speeds: fast & slow speed
- Double motors, for hook & bowl
- Switch ON/OFF
- Equipped with bowl safety cover protector
- Motor with overload protection
- S/s 430 hook, S/S 201 bowl, S/S 304 for rod
- Belt driven
- With castor, fixed feet adjuster
- Compact structure, easy operation and high work efficiency

Note: Untuk mendapatkan hasil yang lebih baik, sebaiknya memakai air dingin (air es)

TYPE	DIMENSION (cm)			BOWL VOLUME (L)	CAPACITY (kg)		POWER (380V/3P/50Hz)	BOWL SPEED (r/min)	MIXING SPEED (r/min)	WEIGHT (kg) Nett Gross
	L	W	H		Flour	Dough				
YQ-SF80	97	57	117	80	30	60	1,8 + 0,75 kW	15 ~ 21	175~233	204 / 209
YQ-SF100	110	62	131	100	37	74	2,8 + 0,75 kW	14 ~ 21	135~255	306 / 311
YQ-SF130	124	68	145	130	50	100	4,5 + 0,75 kW	14 ~ 21	135~255	515 / 560
YQ-SF160	133,5	75	144,5	160	75	150	8 + 1,1 kW	14 ~ 21	135~255	548 / 608

Moulding Machine (Toast Moulders)



CM-238

Features

- This dough roller machine is very suitable for the snack / bakery industry, etc.
- Roll capacity: + 2,000 items / hour
- 2 sets of Adjustable Rollers

TYPE	DIMENSION (cm)			MOULD WIDTH (cm)	WATT	VOLTAGE	GROSS-WEIGHT (kg)
	L	W	H				
CM-238	139	66	106	38	750	380V/50Hz	225

Spiral Mixer with Inverter Motor

GETRA[®]

bali
coolers
www.balicoolers.com



Spiral Mixer adalah jenis mesin yang digunakan untuk mengaduk adonan roti dengan kapasitas besar. Mesin ini dilengkapi dengan dua jenis putaran, yaitu hook (pengaduk) dan bowl (mangkuk). Putaran ganda pada spiral mixer memungkinkan adonan roti untuk diaduk secara efisien dan merata. Kapasitas adonan mencapai 38 kg



LB20



LB30

Features

- Transmission : Belt driven
- Hook and bowl material stainless steel
- Adjustable speed
- Timer : 60 minutes
- Start button
- Emergency stop button
- Motor overload protection
- Shield opening/closing safety protection
- German imported belt, low noise
- Single phase (220V)



LB40



LB50



LB60

TYPE	DIMENSION (cm)			BOWL VOLUME (L)	CAPACITY (kg)		WATT (220V/1P/50Hz)	BOWL SPEED (r/min)	MIXING SPEED (r/min)	WEIGHT (kg) Nett Gross
	L	W	H		Flour	Dough				
LB20	70	40	63	20	8	12	750			60 / 74
LB30	74	44	68	30	12	18	1100			73 / 89
LB40	86,5	48	76	40	16	24	2200	10 ~ 28	110 ~ 240	110 / 133
LB50	91	53,5	76	50	20	30	2500			120 / 140
LB60	91	53,5	82	60	25	38	3000			130 / 150

Note: Untuk mendapatkan hasil yang lebih baik, sebaiknya memakai air dingin (air es)

www.balicoolers.com

Horizontal Dough Mixer

GETRA

bali
coolers

www.balicoolers.com



Selain untuk membuat adonan roti, mixer type horizontal ini sangat cocok untuk membuat adonan mie, kulit pastel, dll.



WHB-15



WHB-25



WHB-50

MODEL	DIMENSION (cm)			CAPACITY		SPEED (rpm)	WATT	VOLTAGE	WEIGHT (kg)	
	L	W	H	Flour	Dough				Nett	Gross
WHB-15	68	52	73	8 kg	12 kg	40	750	220V	59 / 75	
WHB-25	80	62	75	15 kg	23 kg	40	1500	220V	88 / 110	
WHB-50	95	70	95	30 kg	45 kg	40	2200	380V	140 / 160	

Bread Slicer

Mesin pemotong roti tawar



Q25GC



Q31GC



Q41GC

Features

- Power switch ON/OFF
- Feet
- Knob adjuster hopper
- Body color : gray

TYPE	DIMENSION (cm)			CAPACITY (pcs/time)	BREAD THICKNESS	WATT	VOLTAGE	WEIGHT	
	L	W	H					NW/GW (kg)	
Q25GC	75	65	78	25	15 mm	370	220V/1P/50Hz	45 / 61	
Q31GC	75	65	78	31	12 mm	370		45 / 61	
Q41GC	75	65	78	41	9 mm	370		45 / 61	

Pizza Sheeter



Pengatur Ketebalan Adonan

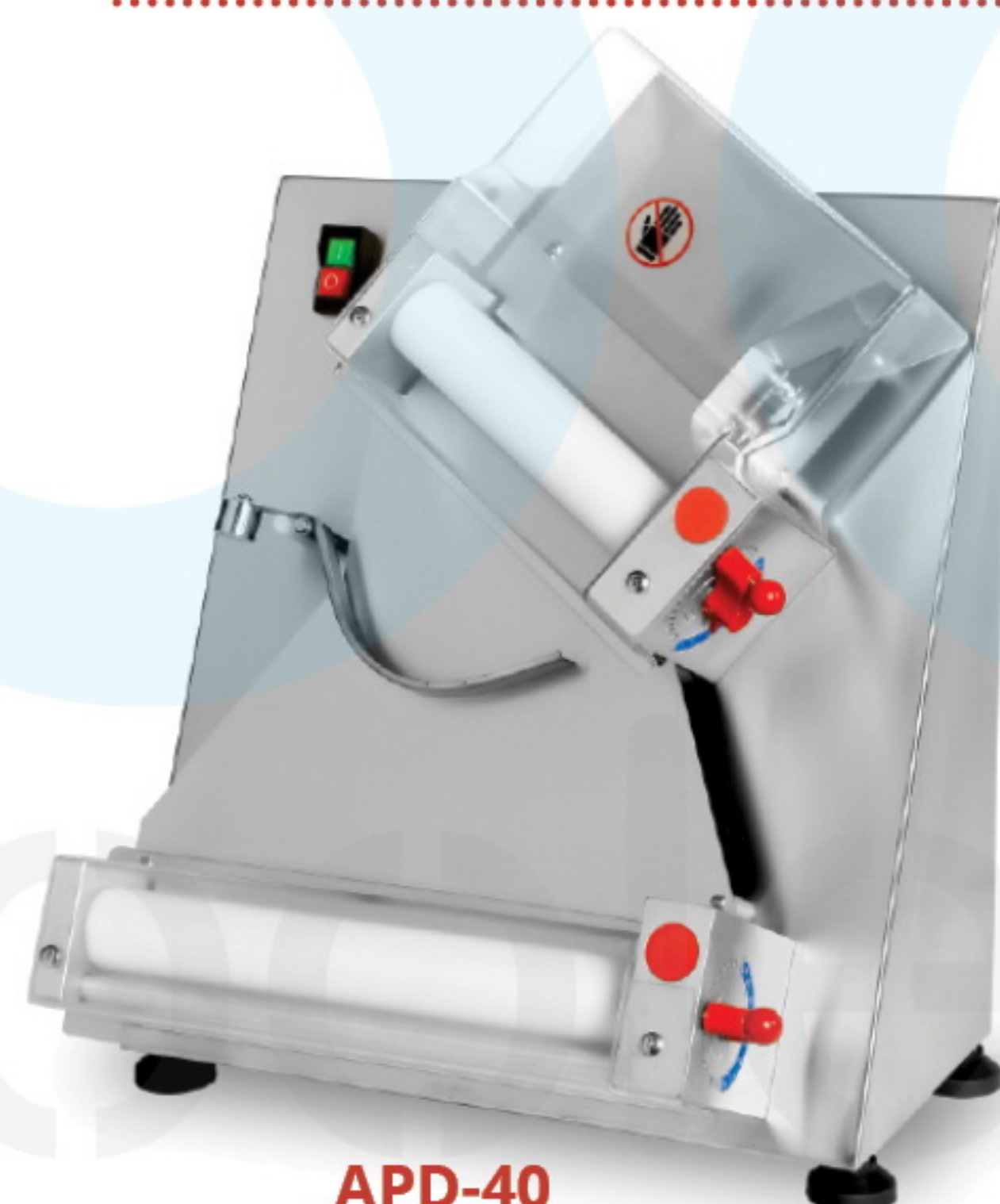

APD-40

Mesin untuk membentuk adonan bulat Pizza diameter 10 ~ 40 CM, juga dapat mencetak pizza bentuk persegi, ketebalan adonan bisa disesuaikan (0,7 ~ 5,4 mm). Berat adonan 50 hingga 500 gram. Body terbuat dari stainless steel 304, Diameter cakram diatur melalui panjang silinder agar dapat mengatur tebal adonan.

TYPE	DIMENSION (cm)			MIX WEIGHT	PIZZA DIAMETER	POWER (220V/1P/50Hz)	WEIGHT (kg)	
	L	W	H				Nett	Gross
APD-40	52,5	56	73	50~500 gr	10~40 cm	370 W	39 / 58	

Dough Sheeter

Mesin pengepres adonan berbentuk lembaran untuk dibentuk selanjutnya, seperti : Kulit risoles, Siomai, Sui Kiau, Wo Tie, Kroket, Lumpia, Pastel, dll



Manual



Thickness range : 1 ~ 18 mm
Roller length : 300 mm
Roller S/s 304

YQ-Y130



Thickness range : 1 ~ 18 mm
Roller length : 388 mm
Roller S/s 304

YQ-Y158

Reversible Dough Sheeter

Menggunakan conveyor belt yang menggerakkan adonan bolak-balik menghasilkan lembaran adonan yang pipih merata. Ketebalan lembaran adonan bisa diatur. Design struktur bisa dilipat

Features

- Belt size: 125x35 cm
- Max dough weight: 2,6 kg
- Accordion structure save space (Folded size: 68x52x59 cm)
- Tabletop, small size, easy to move, easy to carry
- The press wheel is treated with hard chrome (Non-stick dough does not scratch easily)
- Pressure wheel clearance: 0.5mm-26mm
- The dough thickness can be as thin as 3mm

FREE STANDING



CM-330A



CM-520B

LOWER & UPPER CONVEYOR BELT

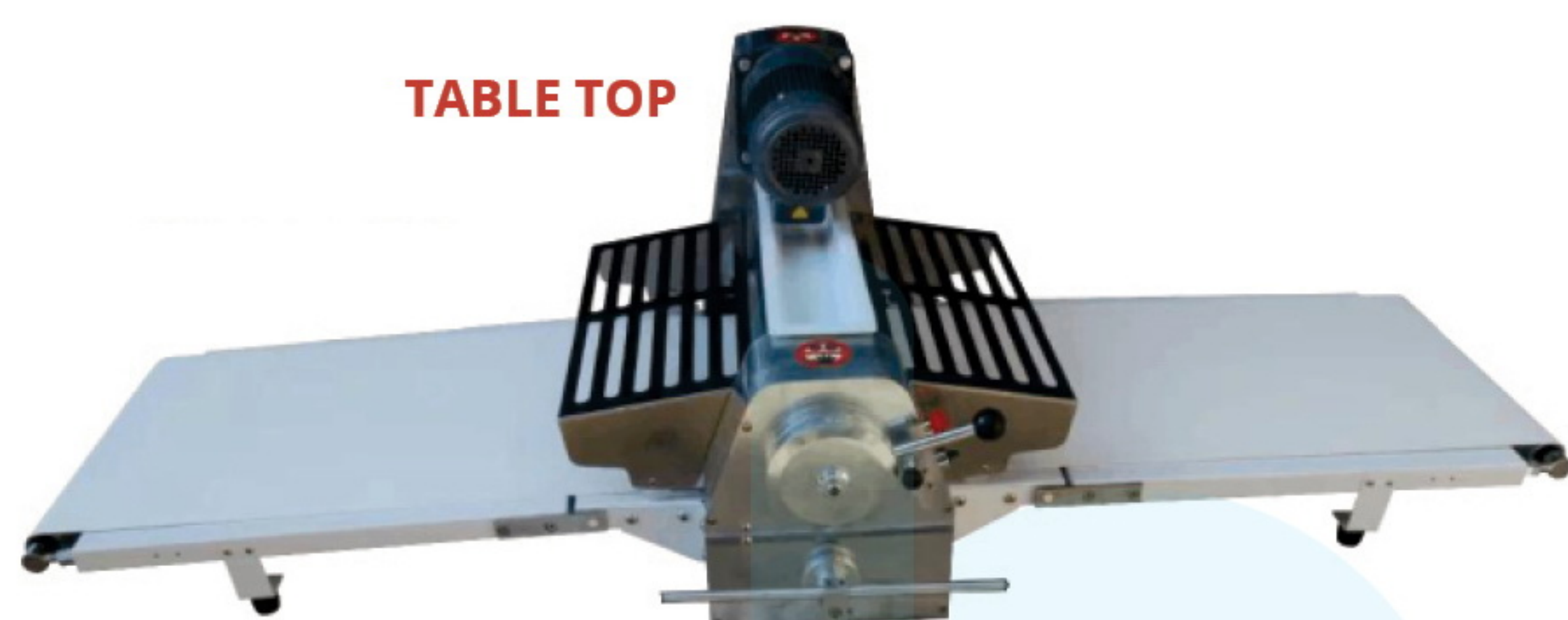

CM-520A



CM350

Features

- Roller material S/s 304
- Capacity: 35 Kg/hour
- Axis width: 30 cm
- Dough thickness: 5 ~ 25 mm
- Equipped with dual conveyor belt system
- S/s body, castor, handwheel

TYPE	DIMENSION (cm)			WATT	VOLTAGE	SPEED (r/min)	WEIGHT (kg) Nett Gross
	L	W	H				
YQ-Y130	60	75	112	1500	220V/1P/50Hz	125	125 / 148
YQ-Y158	75	78	118	4000	380V/3P/50Hz	125	320
CM-330A	130	68	50	400	380V/3P/50Hz	180~300	80 / 100
CM-520A	178	90	62	550	380V/3P/50Hz	133	149 / 182
CM-520B	88	255	118	550	380V/3P/50Hz	133	190 / 260
CM350	110	61	108	3000	220V/1P/50Hz	-	150 / 210

Dough Divider

Manual Dough Divider

Mesin pembagi adonan dengan menarik handle (manual non-electric)
Dengan konstruksi yang kokoh Kapasitas: 36pcs/cycle dengan kisaran berat rata-rata @30-160 g/pcs



CM-36M

Kapasitas : 36 pcs/cycle
Berat @ : 30~160 gram/pcs

Hydraulic Dough Divider

Mesin pembagi adonan semi otomatis menjadi 20 pcs/cycle potongan adonan dengan kisaran berat : @100~800 gr.
Mudah dioperasikan dilengkapi emergency stop untuk pengaman.



CM-20

Kapasitas : 20 pcs/cycle
Berat @ : 100~800 gram/pcs

Features

- Equipment specially made for dividing large dough
- Individual dough weight range: 100g-800gr
- Large number of partitions high work efficiency with instant stop switch

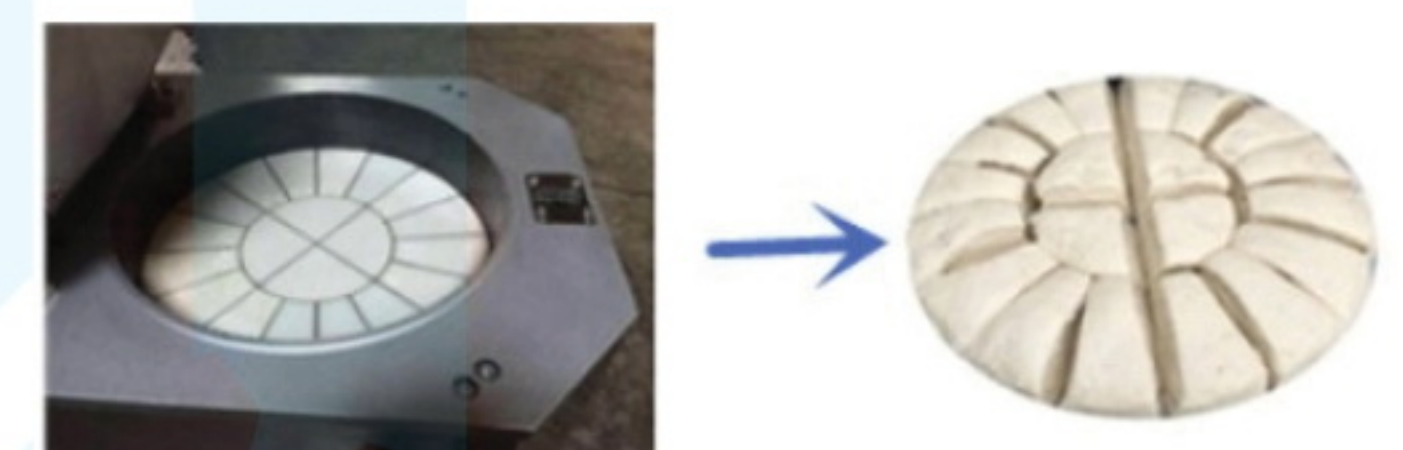

TYPE	DIMENSION (cm)			CAPACITY (pcs/cycle)	VOLTAGE	POWER (W)	WEIGHT (kg)	
	L	W	H				Nett	Gross
CM-36M	37	59	116	36	manual operation, non electric		115	125
CM-20	66	70	106	20	380V/3P/50Hz	1500	320	345

Dough Divider & Rounder

Dough Divider-Rounder adalah mesin pembagi adonan menjadi potongan yang serupa berbentuk semi-bulat hingga bulat



CM-30A

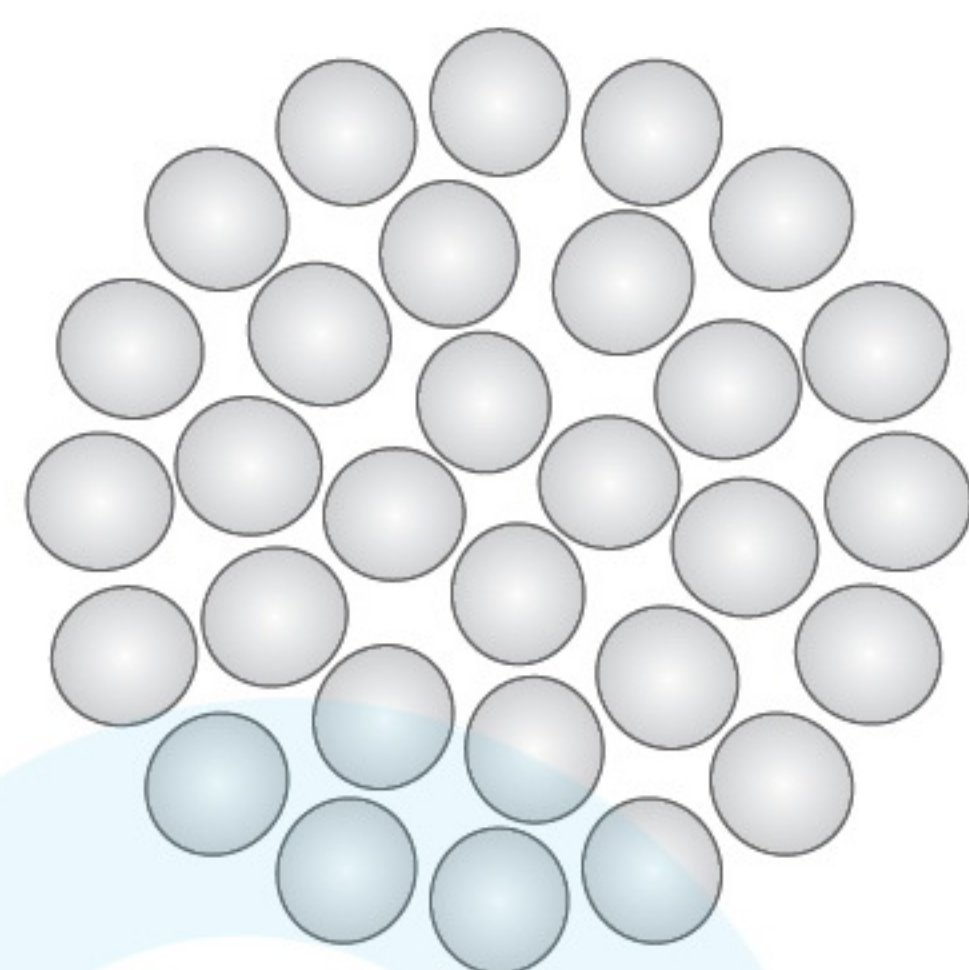

Mesin ini berfungsi ganda: Membagi adonan sekaligus berbentuk semi bulat dan membentuknya menjadi bulat

Kapasitas : 30 pcs/time
Berat @ : 30~100 gram

Dough Divider



CM-336

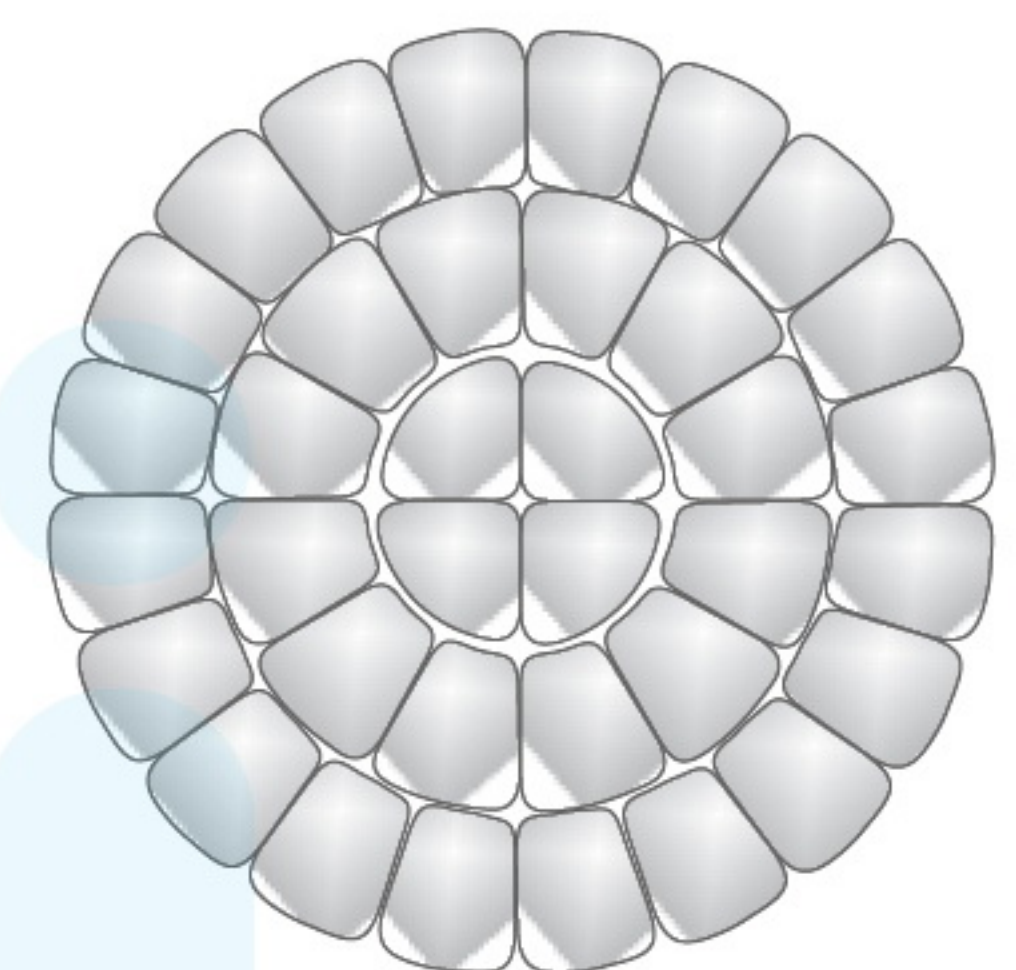

Mesin ini hanya untuk membagi adonan berbentuk semi-bulat

Kapasitas : 36 pcs/time
Berat @ : 30~120 gram

TYPE	DIMENSION (cm)			CAPACITY (pcs/time)	VOLTAGE	WATT	WEIGHT (kg)	
	L	W	H				Nett	Gross
CM-30A	64	54	210	30	380V/50Hz/3P	750	385	450
CM-336	52	42	123	36	380V/50Hz/3P	500	135	190

Proofer

GETRA[®]

bali
coolers
www.balicoolers.com



Proofer berupa kabinet berbahan stainless steel berfungsi untuk membantu adonan roti agar proses fermentasi ragi dapat mengembang secara maksimal. Suhu dan waktu yang diperlukan dalam proses proofing bervariasi dari 32°C sampai dengan 85°C selama 15-20 menit.

Electric



Features

- Stainless steel cabinet
- Humidity Control (60 ~ 80%)
- Digital temperature control
- Aluminium Pan
- Castor Wheel

Features

- Digital temperature control
- Include tray (40*60cm)
- Temperature 85°C
- Stainless steel body, Castor wheel, L steel tray support



TYPE	DIMENSION (cm)			TRAY QTY.	ELECTRICITY		VOLTAGE	WEIGHT(kg) Nett Gross
	L	W	H		Temp. Heater	Humidity Heater		
FJ-15C	52	72	190,5	15 pcs	300 W	1200 W	220V/1P/50Hz	74 / 78
FJ-30C	107	72	190,5	30 pcs	400 W	2400 W		132 / 136
FJ-15GC	48	70	194	15 pcs	500 W	700 W	220V/1P/50Hz	42 / 51
FJ-30GC	98	70	194	30 pcs	700 W	2000 W		76 / 87

Gas



Features

- With aluminium pan
- Stainless steel body
- Removable water pan
- Low pressure
- Castor



(*) Disarankan menggunakan tabung LPG 50 Kg

TYPE	DIMENSION (cm)			INNER SIZE (cm)			GAS POWER (kW)	Gas Cons. (Kg/hour)	TEMP. (°C)	TRAY QTY. (pcs)	WEIGHT(kg) Nett Gross
	L	W	H	L	W	H					
GP-15GC	48	71	183,5	42	61,8	140,3	12	0,87	32 ~ 85	15	40 / 49

Convection Oven with Proofer

GETRA

bali
coolers
www.balicoolers.com



Features (Convection oven)

- 2 directional hot-air convection heating
- Spray steam system with built-in water pump (draws purified water directly)
- 6 memory menus + 3 cooking steps
- Adjustable fan speed
- Proofing & warming function
- Digital display control panel
- Built-in pump that directly pulls purified water

Features (Proofer)

- Include water pan for air humidification
- Distance between trays: 7,5cm
- Switch ON/OFF, thermostat analog, indicator light, Feet



GC05A



Digital controller



Contoh aplikasi



FX-8



Analog thermostat

MODEL	DIMENSION (cm)			POWER (Watt)	VOLTAGE	BAKING PAN (44x32cm)		TEMP. (°C)	WEIGHT NW/GW (Kg)
	L	W	H			Oven	Proofer		
GC05A	67	63	55	3000	220V/1P/50Hz	4 pcs	-	30 ~ 350	36 / 42,5
FX-8	67	63	96	2000	220V/1P/50Hz	-	8 pcs	30 ~ 60	44 / 50

Gas Baking Oven

Features

- Glass door with handle
- Top & bottom burners
- Full stainless steel body
- Adjustable Temp. (30 ~ 300°C)
- Digital Thermostat (top & bottom)
- Digital Temperature Display & Timer
- Top & bottom alarm indicator
- Interior light
- Air valve knob
- Includes aluminum pan
- Wheel (Except RFL-13GD)

LOW PRESSURE



RFL-13GD



RFL-26GD (*)



RFL-39GD (*)

MODEL	DIMENSION (cm)			POWER		Gas Cons. (Kg/hour)	BAKING PAN QTY. (40 x 60)	WEIGHT NW/GW (Kg)
	L	W	H	Electricity (W)	Gas (kW)			
RFL-13GD	171	82	63,5	75	2 x 4,75	0,49	3 pcs	150 / 169
RFL-26GD	171	82	139	150	4 x 4,75	0,98	6 pcs	270 / 298
RFL-39GD	171	82	169	225	6 x 4,75	1,47	9 pcs	353 / 392

(*) Disarankan menggunakan tabung LPG 50 Kg

Gas Baking Oven

GETRA®

bali
coolers
www.balicoolers.com



Seri Gas Baking Oven RFL-GD hadir dengan pintu kaca tahan panas tampil lebih elegan dan lebih mudah memantau hasil pangangan, dengan fitur panel kontrol digital agar mudah dalam pengoperasiannya, serta 2 burner atas dan bawah untuk hasil pangangan lebih merata.

LOW PRESSURED



Features

- Glass door with handle
- Top & bottom burners
- Full stainless steel body
- Adjustable Temp. (30 ~ 300°C)
- Digital Thermostat (top & bottom)
- Digital Temperature Display & Timer
- Top & bottom alarm indicator
- Interior light
- Air valve knob (Except RFL-11GD)
- Includes aluminum pan
- Wheel (Except RFL-11/12GD)

(*) Disarankan menggunakan tabung LPG 50 Kg



RFL-11GD



RFL-12GD



RFL-24GD (*)



RFL-36GD (*)

MODEL	DIMENSION (cm)			POWER		Gas Cons. (Kg/hour)	BAKING PAN QTY. (40 x 60)	WEIGHT NW/GW (Kg)
	L	W	H	Electricity (W)	Gas (kW)			
RFL-11GD	100,5	72	54	50 (220V/1P)	2 x 2,75	0,2	1 pcs	67 / 90
RFL-12GD	131	84	63,5	75 (220V/1P)	2 x 3,9	0,33	2 pcs	96 / 131
RFL-24GD	131	84	139	150 (220V/1P)	4 x 3,9	0,66	4 pcs	187 / 232
RFL-36GD	131	84	167,5	225 (220V/1P)	6 x 3,9	0,99	6 pcs	261 / 321

Electric Baking Oven

www.balicoolers.com



Features

- Digital thermostat
- Black glass door
- Body stainless steel
- Digital Temperature Display & Timer
- Adjustable Temp. (30 ~ 300°C)
- Alarm indicator
- Interior light
- Includes aluminum pan (60x40cm)



ED-11



ED-12



ED-24



ED-36

MODEL	DIMENSION (cm)			INNER SIZE (cm)			POWER (Watt)	VOLTAGE	BAKING PAN QTY. (40 x 60)	WEIGHT NW/GW (Kg)
	L	W	H	L	W	H				
ED-11	92,1	65,5	44	62	52	20	3000	220V/1P/50Hz	1 pcs	40 / 50
ED-12	121	83	57	86,2	65	22,5	7000	380V/3P/50Hz	2 pcs	80 / 95
ED-24	121	83	123	86,2	65	22,5	14000	380V/3P/50Hz	4 pcs	150 / 170
ED-36	121	83	143	86,2	65	22,5	21000	380V/3P/50Hz	6 pcs	180 / 200

(*) Disarankan menggunakan tabung LPG 50 Kg

Premium Gas Oven

GETRA

bali
coolers
www.balicoolers.com



Oven pemanggang gas komersial yang dirancang untuk penggunaan profesional di toko roti, restoran, dan perusahaan bakery lainnya, hadir dalam seri Titanium Coating Stainless Steel, dengan kelebihan permukaan bodi lebih mudah dibersihkan dibanding stainless tanpa lapisan titanium

Bagian base oven, terdapat lapisan marmer yang menambah keunggulan oven ini. Oven ini juga dilengkapi dengan pintu kaca dan lampu internal tahan panas yang memberikan tampilan yang lebih elegan dan memudahkan Anda dalam memantau produk.

LOW PRESSURED

GAS INLET PER DECK



Features

- Titanium Coating Stainless Steel
- Marble on the base of the deck oven
- Digital Thermostat (top & bottom)
- Adjustable Temperature (30 ~ 300°C)
- Digital Temperature Display & Timer
- Interior light
- Air valve knob
- Includes aluminum pan
- Glass door with handle
- Top & bottom burners
- Wheel (except RFL-12)

(*) Disarankan menggunakan tabung LPG 50 Kg



RFL-12SSGA

RFL-24SSGA

RFL-36SSGA

MODEL	DIMENSION (cm)			POWER 220V/1P		Gas Cons. (Kg/hour)	BAKING PAN QTY. (40 x 60)	WEIGHT NW/GW (Kg)
	L	W	H	Electricity (W)	Gas (kW)			
RFL-12SSGA	142	105,5	82	75	2 x 2,2	0,32	2 pcs	159 / 189
RFL-24SSGA	142	105,5	132	150	4 x 2,2	0,64	4 pcs	310 / 360
RFL-36SSGA	142	105,5	184	225	6 x 2,2	0,96	6 pcs	479 / 539

Combi Deck Oven + Proofer

LOW PRESSURED



RFL-12SS+FJ10 (*)
Include 2 tray

RFL-24SS+FJ10 (*)
Include 4 tray

Kombinasi deck oven dengan proofer lebih praktis dan menghemat tempat. Oven dioperasikan menggunakan gas LPG sedangkan Proofer menggunakan tenaga listrik.

MODEL	DIMENSION (cm)			POWER		Gas Cons. (Kg/hour)	BAKING PAN CAP.		GW/NW(kg)
	L	W	H	Watt	Gas (kW)		Oven	Proofer	
RFL-12SS+FJ10	131	82	152,5	1700	2 x 3,9	0,33	2 pcs	10 pcs	180 / 215
RFL-24SS+FJ10	131	82	200	1775	4 x 3,9	0,66	4 pcs	10 pcs	261 / 275

(*) Disarankan menggunakan tabung LPG 50 Kg



Gas Baking Oven

Oven ini dirancang khusus untuk memanggang roti dengan pemanggang atas dan bawah, suhu panas oven bisa diatur (30 ~ 300°C), Pelat terbuat dari Stainless steel. Dengan panel digital untuk memudahkan pengoperasiannya dan dilengkapi dengan pengatur suhu analog dan thermometer digital juga sudah dilengkapi timer / pengatur waktu yang berfungsi juga untuk mematikan aliran gas jika seting waktu sudah mencapai.



Features

- Thermostat analogue
- Stainless steel body

Features

- Digital panel control
- Stainless steel body



RFL-11SSGC



RFL-11SSGC.E
RFL-12SSGC.E



RFL-24SSGC.E (*)



RFL-36SSGC.E (*)

MODEL	DIMENSION (cm)			INNER SIZE (cm)			POWER (220V/1P)		Gas Cons. (Kg/hour)	Baking Pan Qty. (60 x 40)	NW/GW (kg)
	L	W	H	L	W	H	Electric (W)	Gas (kW)			
RFL-11SSGC	103	65	54	61	50,5	19	80	2 x 2,2	0,32	1 pcs	68 / 75
RFL-11SSGC.E	103	65	54	61	50,5	19	80	2 x 2,2	0,32	1 pcs	68 / 75
RFL-12SSGC.E	131	82,5	64	86	67,5	22	100	2 x 3,3	0,48	2 pcs	80 / 95
RFL-24SSGC.E	131	82,5	140,5	86	67,5	22	200	4 x 3,3	0,64	4 pcs	205 / 220
RFL-36SSGC.E	131	82,5	170	86	67,5	22	300	6 x 3,3	0,96	6 pcs	298 / 315

(*) Disarankan menggunakan tabung LPG 50 Kg

Gas Pizza Deck Oven

Oven ini dirancang khusus untuk memanggang pizza dengan pemanggang atas dan bawah, suhu panas oven bisa diatur (60 ~ 400°C), bodi terbuat dari stainless steel.



RFL-12PGC



RFL-24PGC (*)

Features

- Top & bottom burners
- Digital thermostat, with memory menu
- With stone base
- Including 40x60 cm baking tray
- Stainless steel body
- Temperature 60 ~ 400°C



Digital controller

MODEL	DIMENSION (cm)			INNER SIZE (cm)			POWER (220V/1P)		Gas Consum (Kg/hour)	BAKING PAN Quantity (60 x 40)	NW/GW (kg)
	L	W	H	L	W	H	Electric	Gas (kW)			
RFL-12PGC	131	82,5	61,5	86	67,5	22	100 W	2 x 3,45	0,76	2 pcs	85/100
RFL-24PGC	131	82,5	140,5	86	67,5	22	200 W	4 x 3,45	1,52	4 pcs	210/225

Pizza Oven (Napoli Series)

GETRA®



www.balicoolers.com

Pizza oven berbentuk dome (kubah) ini dirancang sebagai solusi rapid baking dengan suhu operasional hingga $\pm 500^{\circ}\text{C}$, serta untuk pengoperasian heavy duty dengan temperatur yang lebih stabil dan merata. Menggunakan konstruksi Steel Fiber Casting berlapis Mosaic Tile, oven ini mampu menjaga suhu stabil (anti temperature drop) meskipun digunakan secara heavy duty, menghasilkan pizza yang matang sempurna, renyah di bagian luar dan lembut di bagian dalam. Dilengkapi Japan Omron Temperature Controller untuk kemudahan mengatur suhu.

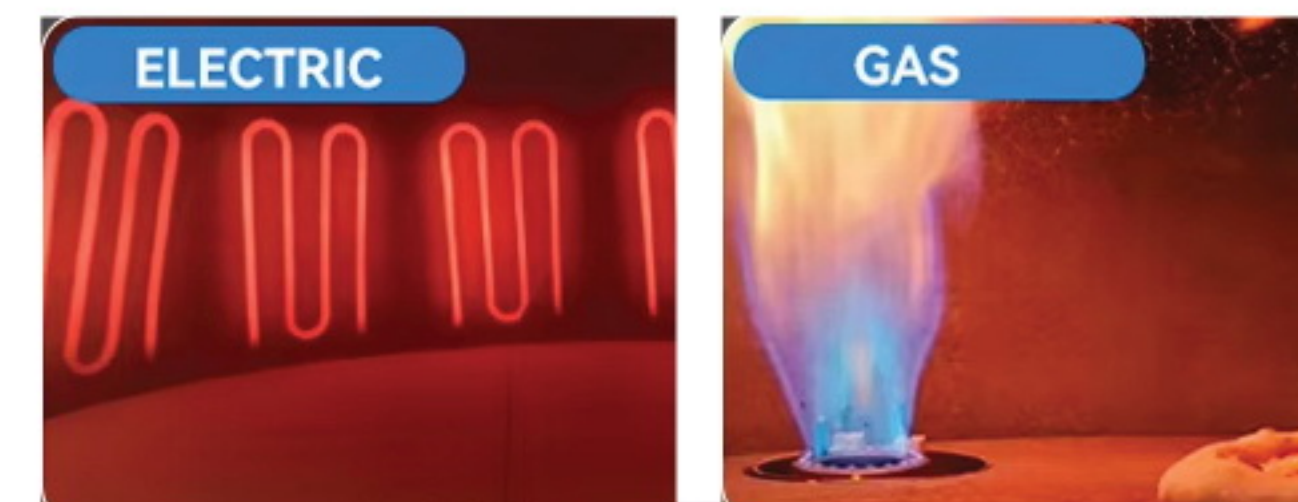

Exhaust chimney dihubungkan ke ducting hood (tidak termasuk)



Features

- Thermostat: Japan brand Omron controller
- Durable resistant steel fiber casting material
- Capacity: 30 second/cycle (diameter pizza $\varnothing 12''$)
- Top exhaust chimney
- Dome top design
- Heating tubes are arranged in a circle around the oven and underneath the stone slab. This ensures the pizza heats evenly and is served quickly
- Temperature: 50 ~ 500°C

TYPE	DIMENSION(cm)			INNER SIZE (cm)	BOTTOM-CHAMBER SIZE (cm)	POWER		Gas Cons. (Kg/hour)	Cap. $\varnothing 12''$	TEMP. ($^{\circ}\text{C}$)	WEIGHT (kg)
	L	W	H			Electricity	Gas Power				
Electric	120	135	190	80x80	$\varnothing 114$	12kW(380V)					940/975
Gas	120	135	190	80x80	$\varnothing 114$	200W(220V)	18 kW	1,8	30 sec/cycle	50-500	940/975
Electric	150	165	200	110x110	$\varnothing 144$	12kW(380V)					1440/1600
Gas	150	165	200	110x110	$\varnothing 144$	200W(220V)	27 kW	2,7			1440/1600

(*) Untuk unit dengan Gas LPG, disarankan menggunakan tabung LPG 50 Kg



Convection Oven

GETRA®

bali
coolers
www.balicoolers.com



Electric & Gas Convection Oven



LOW PRESSURE



QH-5D / QH-5Q



QH-8D / QH-8Q (*)

Features

- Taiwan CAHO digital temperature controller
- 1.2 mm Stainless steel thickness inside / outside
- Steam
- High power fan

TYPE	DIMENSION (cm)			BAKING PAN QTY (40 x 60)	POWER		Gas Cons. (Kg/hour)	TEMP. (°C)	WEIGHT (kg)
	L	W	H		Electricity (W)	Gas (kW)			
QH-5D	90	113,5	77	5 pcs	7500 (380V)	-	-	~300	200
QH-8D	90	113,5	125	8 pcs	14500 (380V)	-	-	~300	300
QH-5Q	90	116,5	73	5 pcs	650 (220V)	7,5	0,54	~300	200
QH-8Q	90	116,5	142	8 pcs	1300 (220V)	18	1,31	~300	330

(*) Disarankan menggunakan tabung LPG 50 Kg

Electric Convection Oven



SC-4A

Features

- Thermostat knob
- Timer knob
- Double glass door
- S/s pipe door handle
- Indicator light
- Manual spraying function
- Door switch (fan & heater stop when door open)

TYPE	DIMENSION (cm)			BAKING PAN QTY (pcs)	HEATER (pcs)	POWER (kW)	VOLT.	TEMP. (°C)	NW (kg)
	L	W	H						
SC-4A	60	59,5	57	4 x (43,5x31,5 cm)	2	2,6	220V/1P	~300	44

www.balicoolers.com

Convection Oven

GETRA®

bali
coolers
www.balicoolers.com



Convection Oven ini dirancang untuk kebutuhan dapur profesional dengan sistem hot air circulation yang memastikan panas merata di setiap tray. Dilengkapi spray steam system, oven ini mampu menjaga kelembapan produk, menghasilkan roti dan pastry dengan tekstur yang bagus. Cocok untuk Bakery, hotel, restoran, central kitchen, catering, cafe.

Electric Convection Oven



HEA-5

HEA-8

Features

- Spray / steam control for internal humidity
- Fan/Hot air circulation
- Auto water function
- Include 40x60cm pans
- Body S/s 430, internal chamber stainless steel
- Adjustable feet (5-pan), castor (8-pan), anti-slip handle door
- Control panel (temperature, timer, switch ON/OFF)
- Internal light
- With a door interlock (inching) switch for safety protection

Gas Convection Oven



LOW PRESSURE



HGA-5

HGA-8 (*)

TYPE	Inner size (cm)			Tray rack Size (cm)
	L	W	H	
HEA-5	70	50	50	45,6x60x49,8/9
HEA-8	70	50	77,5	46,5x60x76,8/9
HGA-5	70	50	50	46,5x60x49,8/9
HGA-8	70	50	77,5	46,5x60x76,8/9

TYPE	DIMENSION (cm)			BAKING PAN QTY (40 x 60)	POWER		Gas Cons. (Kg/hour)	TEMP. (°C)	WEIGHT NW/GW (kg)
	L	W	H		Electricity (W)	Gas (kW)			
HEA-5	93	90	83	5 Pcs	7400 (380V)	-	-	50~350	116/141
HEA-8	93	90	110	8 Pcs	10800 (380V)	-	-	50~350	153/171
HGA-5	93	90	83+13	5 Pcs	400 (220V)	10	0,65	50~350	116/145
HGA-8	93	90	110+13	8 Pcs	800 (220V)	12	0,78	50~350	157/175

(*) Untuk unit dengan Gas LPG, disarankan menggunakan tabung LPG 50 Kg

www.balicoolers.com



Electric Speed Oven

Oven yang menggunakan teknologi kombinasi antara microwave + convection oven untuk memanaskan makanan dengan lebih cepat (dalam waktu 30 detik) menghasilkan produk yang garing di luar namun tetap moist di dalam.

Sesuai untuk bisnis kuliner terutama untuk western food restaurant, toko pizza dan sandwich, convenience store, cafe shop, corner bar atau Hotel



USB port

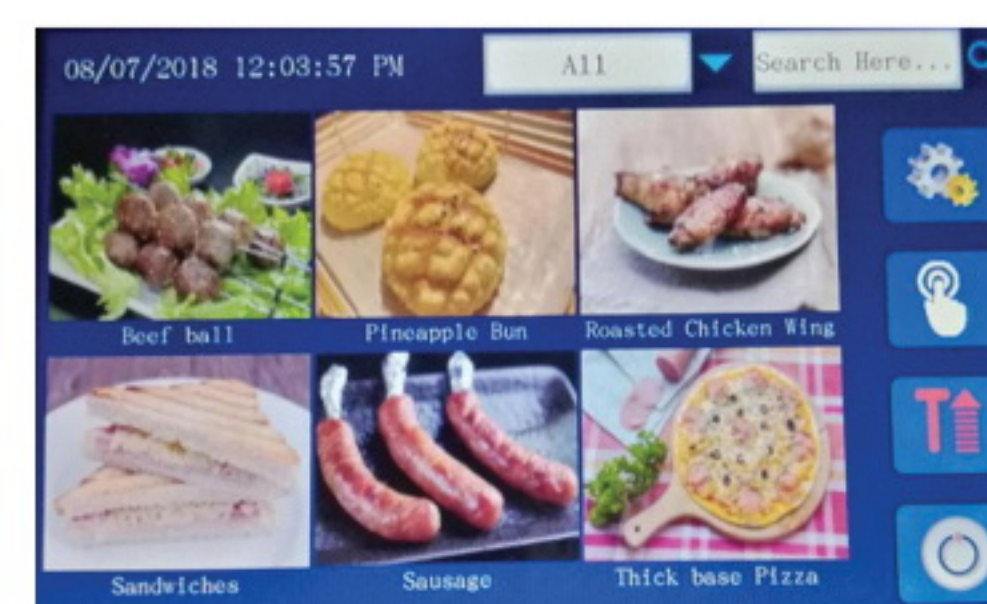

Contoh Menu Program



Air filter



NT-ProSiT

Features

- 5" touch screen digital controller, 1024 menu storage
- 15 cooking stages
- Cooking mode: Vertical Hot Air Impingement+Microwave (*)
- + Bottom circulating hot air
- Adjustable blower speed from 10% to 100% in 10% increment
- Catalytic Converter
- Max temperature: 280°C
- Usb port, air filter
- Stainless steel body
- Power switch, adjustable feet

Aksesoris (termasuk) :

- Round pizza pan
- Teflon mesh basket
- Round teflon mesh pad
- Oven shovel
- Inner hall grill



(*) Metode memanaskan yang menggunakan konveksi udara panas vertikal berkecepatan tinggi untuk hasil cepat dan merata, tekstur yang renyah di bagian luar, dan tetap moist di dalam. Kombinasi ini memungkinkan memanaskan cepat dengan kecepatan microwave dan peningkatan warna kecokelatan yang menarik serta tekstur akibat hentakan udara panas.

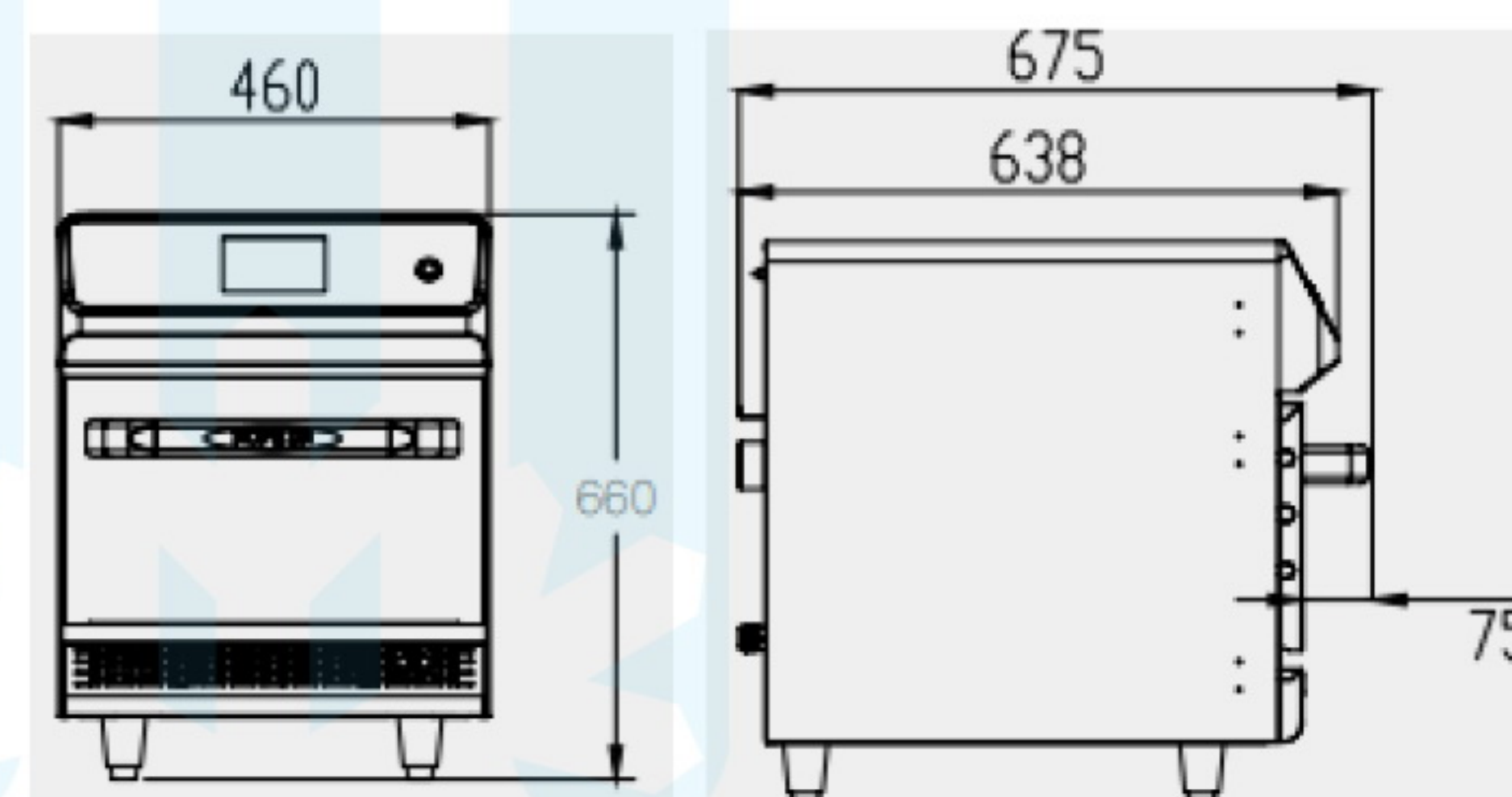

MODEL	DIMENSION (cm)			CHAMBER SIZE(cm)	CAPACITY (L)	WATT (220V/1P/50Hz)	WEIGHT NW/ GW (Kg)
	L	W	H				
NT-ProSiT	46	67,5	66	30.5x30.5x18.5	17	3500	64 / 88,5

Electric Sweet Potato Baker



ZB-KS298

Mesin pemanggang ini dirancang khusus untuk memanggang produk ubi (ubi cilembu, kentang manis, ubi ungu, ubi jalar orange) menghasilkan cairan manis alami dengan tekstur lembut. Kabinet roaster dengan 2 chamber pemanggaan (middle & bottom chamber) menggunakan sistem rotary dan knob thermostat untuk hasil pemanggaan lebih merata dan efisien.

Features

- Timer 120 minute
- Rotating basket 16 pcs
- With a heat-insulating lamp
- Lava rock on top deck
- Thermostat, castor, handle door, drawer, operates without fan
- Stainless steel body
- 2 layer glass door

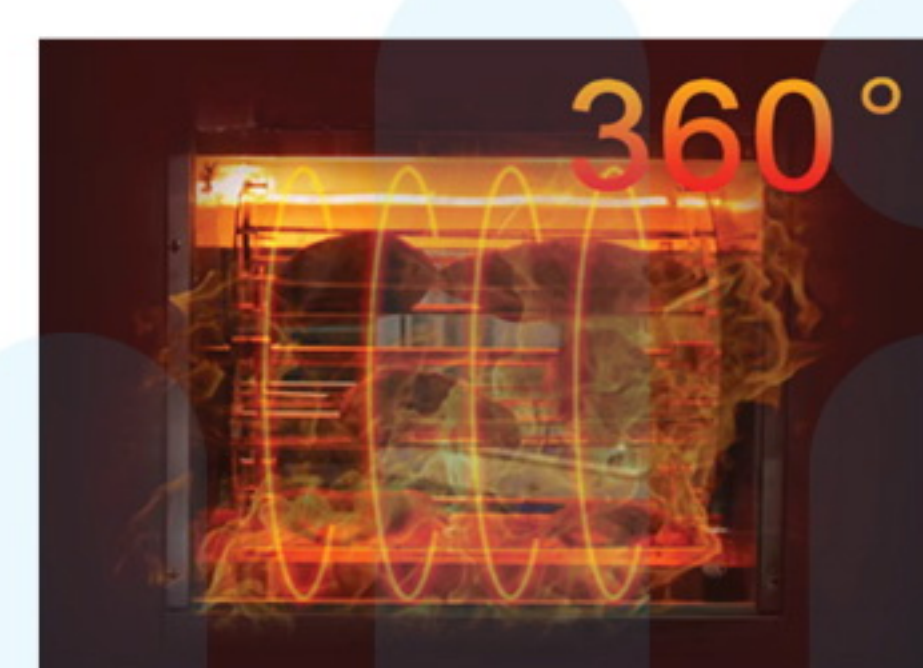

Rotating roasting system for even heating



Top deck with lava rocks for keep warm and display



Rotating basket

MODEL	DIMENSION (cm)			CAPACITY (Kg/Cycle)	POWER (Watt)	VOLTAGE	BASKET (Pcs)	TEMP. (°C)	WEIGHT NW/GW (Kg)
	L	W	H						
ZB-KS298	62	53	124	10	2400 x 2	220V/1P/50Hz	16	50 ~ 250	70 / 80

Commercial Electric Pizza Oven

GETRA

bali
coolers
www.balicoolers.com



Oven elektrik khusus untuk memanggang Pizza dengan kapasitas 1 loyang pizza berdiameter 18" (Ø45 cm), base kompartemen dari stone. Front panel dari stainless steel dan window glass. Oven ini dilengkapi 2 buah heater atas dan bawah untuk mempercepat pemerataan panas.



EPZ-18

Features

- Stainless steel front panel
- Glass window
- Adjustable Temperature (50 ~ 350°C)
- Top & bottom heater
- Stone base deck oven
- Indicator light
- Power switch

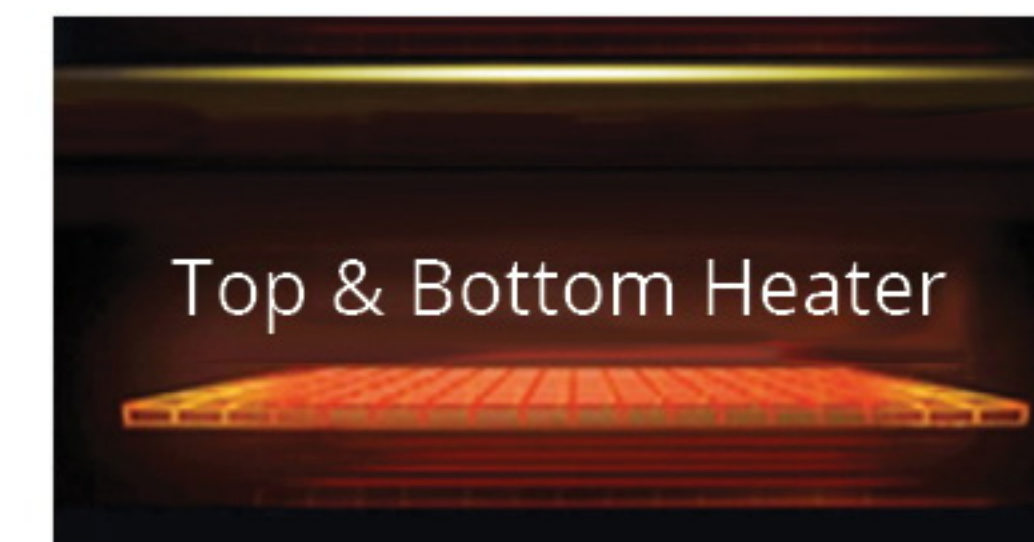

TYPE	DIMENSION (cm)			CHAMBER (cm)			CAPACITY (1 pcs.)	POWER (220V/1P)	TEMP. (°C)	WEIGHT Nett / Gross
	L	W	H	L	W	H				
EPZ-18	68,5	67,5	28	50	50	11,5	18" pizza	2 KW	50 ~ 350	25 / 26,5

Gas Pizza Oven

Gas pizza oven dengan pizza stone Ø 32 cm, dengan motor rotasi otomatis pizza stone, hasil pangangan merata



LOW PRESSURE



WN-026TR-13A

Features

- Rotating turntable motor is located below the unit with USB plug
- Diameter stone Ø32cm
- Hole dimension 34,5x13,5 cm
- Portable design
- Material: anodized, S/s 201
- Piezo ignition
- Digital display temperature
- Temperature: 50~350°C
- Capacity 1 pcs (60~90 second)

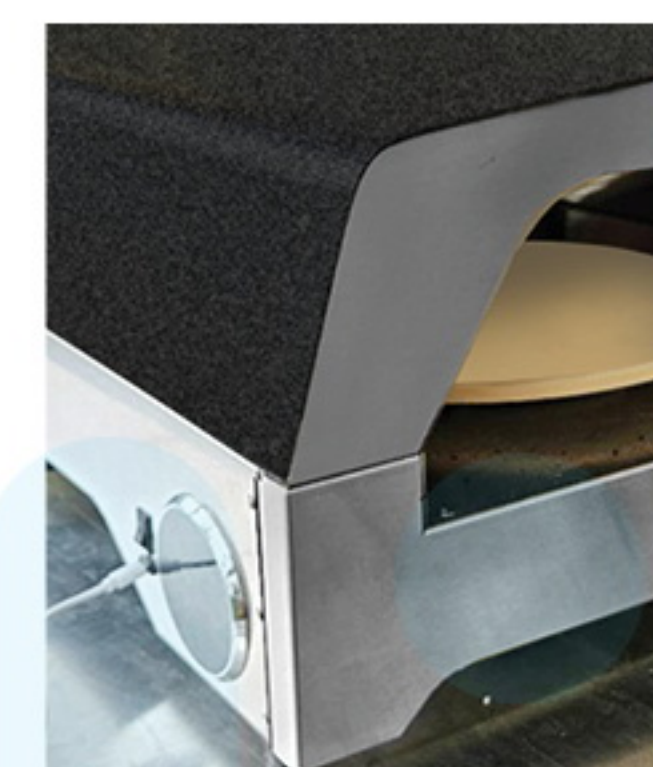

TYPE	DIMENSION (cm)			PIZZA STONE	GAS CONSUMP. (Kg/Hour)	CAPACITY (Pcs)	NW/GW (kg)
	L	W	H				
WN-026TR-13A	58	48	30	Ø 32cm	0,524	1	20 / 24

www.balicoolers.com

Gas Rotary Oven

GETRA

bali
coolers
www.balicoolers.com



Features

- Include 18 trays + 1 trolley
- With steam function
- Digital controller



ET-18B



XZ-32Q



Also available for Diesel & Electric

32 Trays
Include 1 Trolley

Features

- Olympia brand LPG burner
- Taiwan CAHO digital temperature controller
- Steam function

Note: Biaya instalasi 5% *) Disarankan menggunakan tabung LPG 50 Kg

TYPE	DIMENSION (cm)			BAKING PAN QTY. (40x60cm)	POWER		Gas Cons. (Kg/hour)	TEMP. (°C)	WEIGHT (kg)
	L	W	H		Watt	Gas			
	ET-18B	98	150	202	18 pcs	2000 (220V/1P)	36 kW	3,76	30~350
XZ-32Q	182	260	245	32 pcs	3500 (380V/3P)	37 kW	2,7	30~300	1900

Nastar Machine

Membuat kue nastar kini lebih efisien dan praktis dengan kombinasi 2 mesin: Mesin pencetak adonan sekaligus isian nastar untuk membentuk adonan sekaligus mengisi berbagai varian isian seperti selai nanas, cokelat / kacang.

Dough Rounding
Membulatkan adonan nastar

Features

- Ball diameter: 10~50 mm
- S/s 304
- Disk materi: alumunium (with teflon coating)

Nastar Machine

Mesin pembentuk sekaligus pengisi nastar dengan aneka jenis selai.



P110-1



P110B

PLC controller



Dough hopper

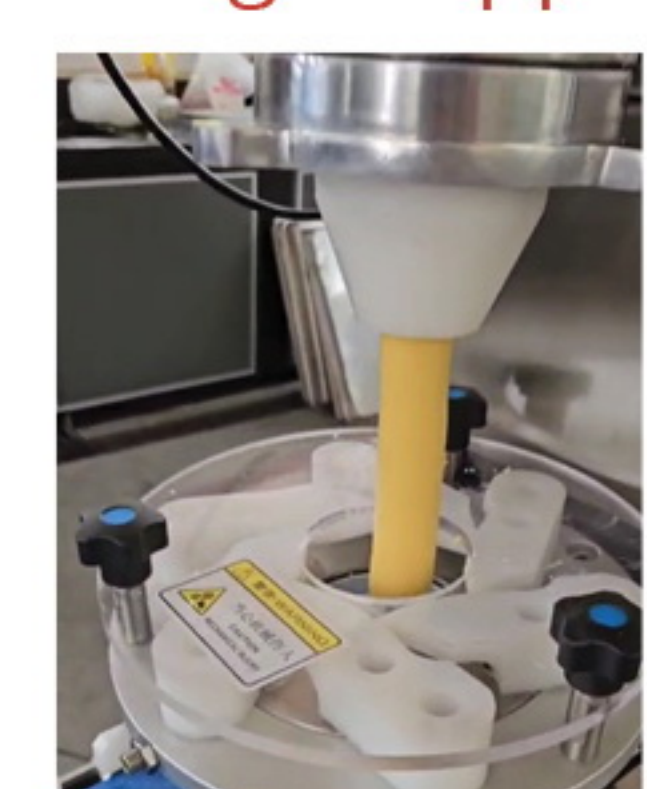

Features

- Weight per bun: 10~125g
- Diameter bun: 10~50 mm
- Dough hopper: 10Kg
- Filling hopper: 5Kg
- S/s 304

Catatan:

- Resep adonan kemungkinan harus disesuaikan (adjustment) apabila sebelumnya proses pembuatan dilakukan secara manual.

TYPE	DIMENSION (cm)			PRODUCTION CAPACITY	VOLTAGE	POWER (W)	WEIGHT (kg) NW / GW
	L	W	H				
P110B	80	125	170	60 pcs/min	220V/1P/50Hz	1100	170 / 280
P110-1	35	32	80	60~99 pcs/min		100	50 / 60





Mooncake Filling Machine

GETRA

bali
coolers
www.balicoolers.com



Optional Mold of Mooncake (Exclude),
Harga /mould Rp. 3,15 jt, pilih salah satu:

-  Ø63 mm, 100g, mooncake height: 2,5~5cm
-  Ø70 mm, 120g, mooncake height: 2,3~5cm
-  Ø58 mm, 80g, mooncake height: 1,5~5cm
-  Ø65 mm, 110g, mooncake height: 1,8~5cm
-  Ø50 mm, 60g, mooncake height: 1~5cm

Features filling

- PLC controller
- Include one mold forming (Ø63mm, 100g)
- Body stainless steel
- Conveyor belt
- Castor with stopper

Features forming

- PLC controller
- Weight per bun: 20 ~130 g
- Filing hopper: 5 ~ 25L/cycle
- Dough hopper: 5 ~ 25L/cycle
- Conveyor belt, Body S/s 201
- Castor with fixed feet



Mesin Pencetak (Forming Model)

Mesin Filling Mooncake Otomatis

Note :

- Mesin forming harus menggunakan kompresor udara (Tidak termasuk) :
- Air displacement : 280 L/min, pressure : 0,8 bar, speed 2800rpm
- Air compressor 220V/1P/50Hz, power: 3000 W
- Resep adonan kemungkinan harus disesuaikan (adjustment) apabila sebelumnya proses pembuatan dilakukan secara manual.

TYPE	DIMENSION(cm)			CAPACITY (pcs/hour)	WATT	VOLTAGE	WEIGHT (kg) Nett Gross
	L	W	H				
ML-101	110	100	140	40~80	2000	220V/1P/50Hz	340 / 400
	160	155	143	40~80	2000		108 / 128

Semi Automatic Egg Tart Machine

www.balicoolers.com

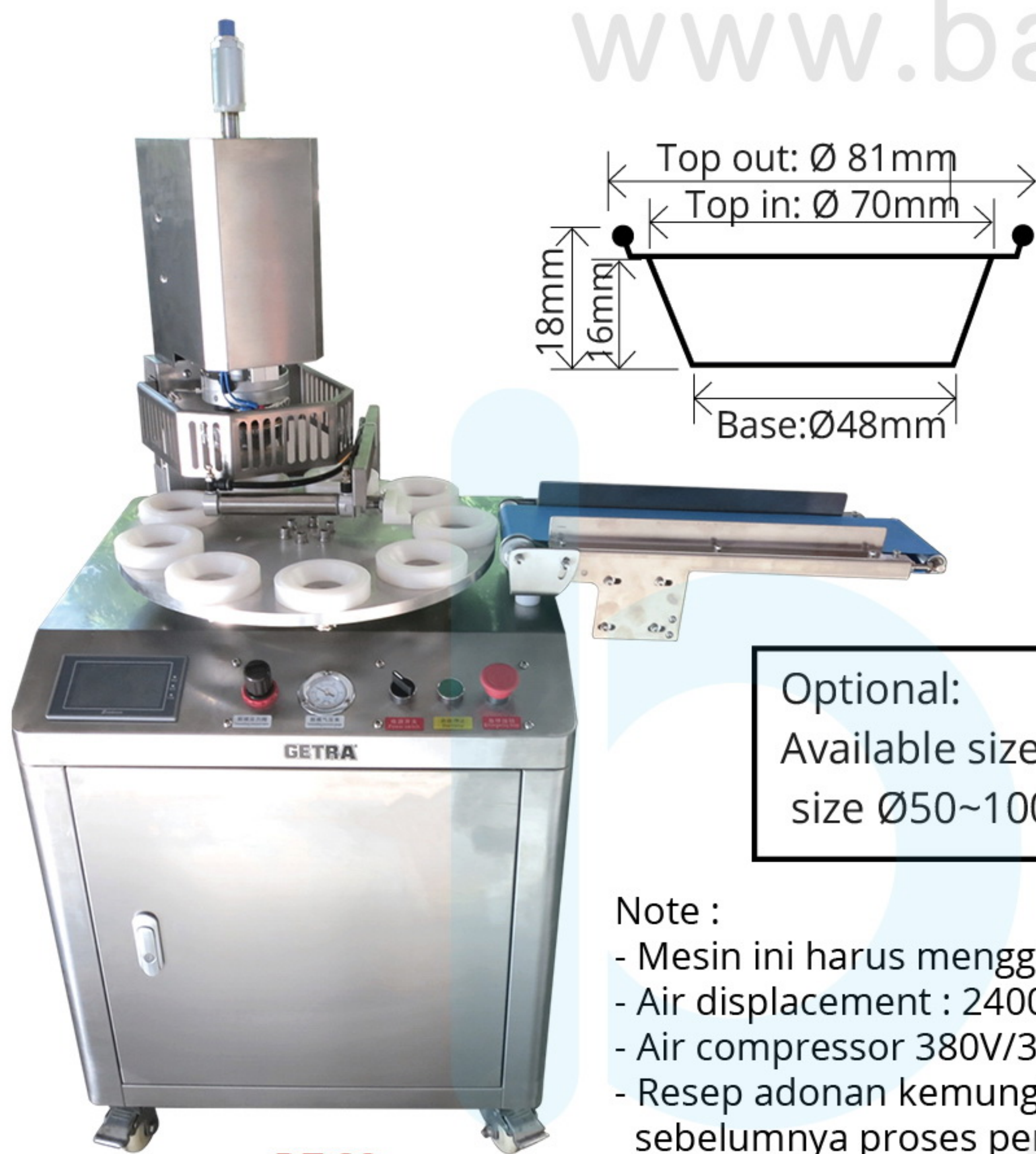

DT-38

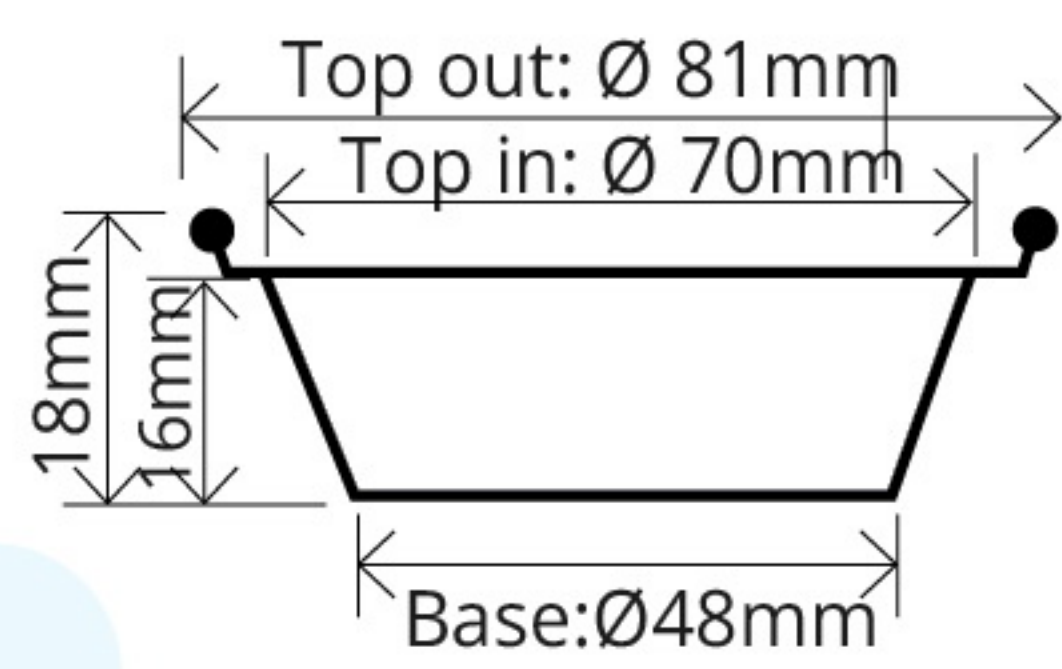

Thickness: 0,04 mm,
weight: 0,9g
Material:
aluminium foil



Optional:
Available size top diameter
size Ø50~100mm

Note :

- Mesin ini harus menggunakan kompresor udara (Tidak termasuk)
- Air displacement : 2400 L/min, pressure : 7 mpa
- Air compressor 380V/3P/50Hz 3KW
- Resep adonan kemungkinan harus disesuaikan (adjustment) apabila sebelumnya proses pembuatan dilakukan secara manual.

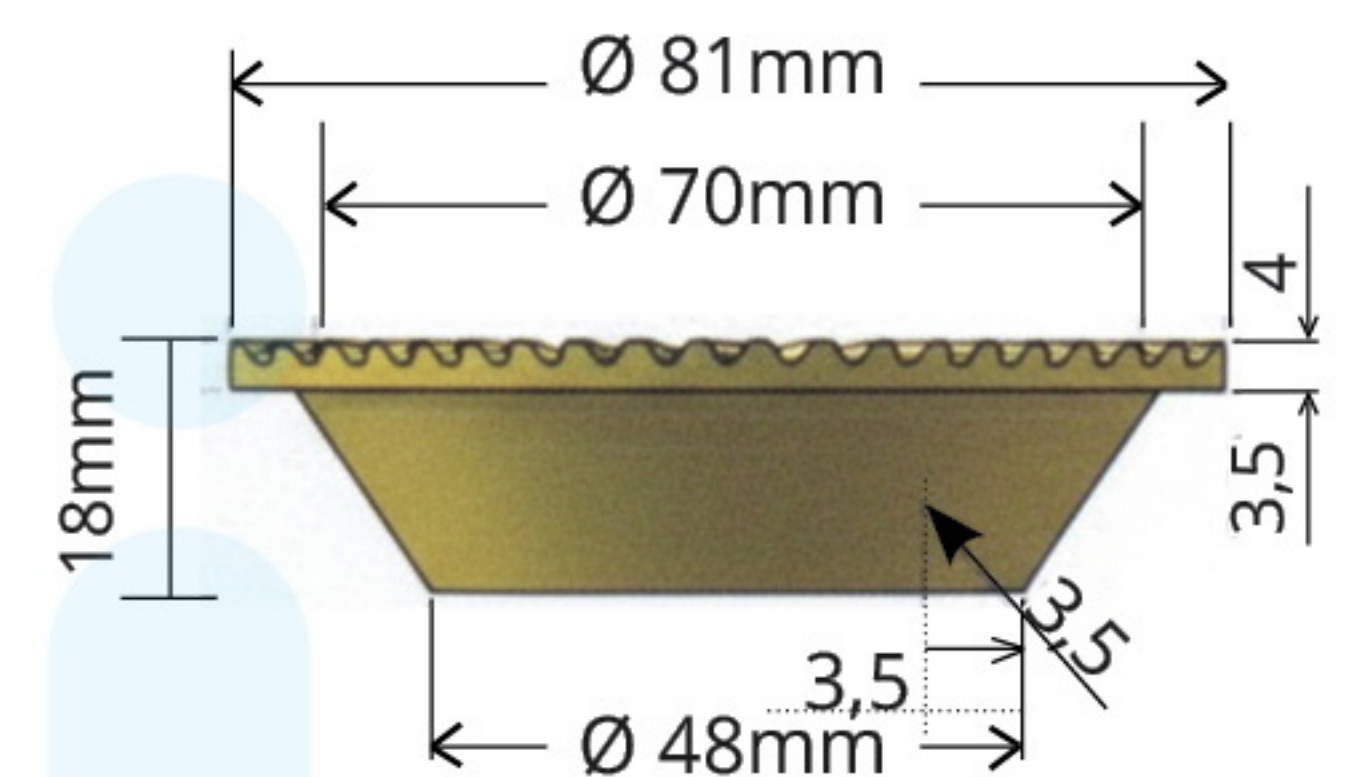

Features

- Digital controller
- Tart cup diameter: 50~100mm
- Conveyor belt
- Stainless steel body S/s304
- Emergency stop
- Castor/wheel

TYPE	DIMENSION (cm)			CAPACITY (pcs/hour)	WATT	VOLTAGE	WEIGHT (kg) Nett Gross
	L	W	H				
DT-38	59	59	125	1500~1800	400	220V/1P/50Hz	125 / 150

Commercial Steam Bun Machine

GETRA

bali
coolers
www.balicoolers.com



BY22-PAO

Mesin Bakpao Otomatis



Features

- Material contact with food S/s 304
- Body material S/s
- Controller
- Conveyor belt, Castor
- Can filling bun with: meat, vegetables, beans, paste.
- The machine is not affected by temperature when making steamed buns
- Weight per bun: 30~150gr/pcs

Catatan:

Komposisi isian maksimum adalah 1:1, jika berat bun 100 gram, maka kulit bun 50 gram : isian 50 gram.



Note :

- Mesin forming harus menggunakan kompresor udara (Tidak termasuk) :
- Air displacement : 280 L/min, pressure : 0,8 bar, speed 2800rpm
- Air compressor 220V/1P/50Hz, power: 3000 W
- Resep adonan kemungkinan harus disesuaikan (adjustment) apabila sebelumnya proses pembuatan dilakukan secara manual.

TYPE	DIMENSION (cm)			CAPACITY (pcs/hour)	HOPPER (L)		POWER 220V/1P/50Hz	WEIGHT /bun gram/pcs	WEIGHT NW/GW (kg)
	L	W	H		Filling	Dough			
BY22-PAO	146	72,8	148	1000 ~ 2000	5~15	6~10	1000 W	30~150	128/158

Automatic Pastel Machine

Features

- Include 1 pastel mold (10x5cm, standard)
- Weight per pec: 7 ~ 10 gr/pcs
- Filling hopper: 3 Kg
- Dough hopper: 3 Kg
- Voltage: 220V/1P/50Hz
- Thickness adjuster, Castor, Body S/s, Knob ON/OFF

Forming mold standard:



Size: 10 x 5 cm



Filling hopper



Flour hopper



XJT-J4000

Additional molds, choose 1 model

- | | | | |
|----------------------------|--|----------------------------|--|
| 1. Size (LxW) : 6 x 6 cm | | 10. Size (LxW) : 7 x 4 cm | |
| 2. Size (LxW) : 6 x 6 cm | | 11. Size (LxW) : 13 x 6 cm | |
| 3. Size (LxW) : 13 x 6 cm | | 12. Size (LxW) : 13 x 6 | |
| 4. Size (LxW) : 10 x 10 cm | | 13. Size (LxW) : 5 x 5 cm | |
| 5. Size (LxW) : 13 x 6 cm | | 14. Size (LxW) : 8 x 8 cm | |
| 6. Size (LxW) : 13 x 6 cm | | 15. Size (LxW) : 6 x 6 cm | |
| 7. Size (LxW) : 13 x 6 cm | | | |
| 8. Size (LxW) : 13 x 6 cm | | | |
| 9. Size (LxW) : 5 x 5 cm | | | |

Note:

- Material daging/sayur/isian yang dimasukkan harus sudah digiling halus dan sudah tidak mengandung urat
- Resep adonan kemungkinan harus disesuaikan (adjustment) apabila sebelumnya proses pembuatan dilakukan secara manual.

TYPE	DIMENSION (cm)			CAPACITY (pcs/hour)	POWER (Watt)	VOLTAGE	WEIGHT NW/GW (Kg)
	L	W	H				
XJT-J4000	128	44	80	4000	2500	220V/1P/50Hz	130 / 170



Dumpling Maker

Semi-Automatic Table Type

Membuat dumpling dengan isian (filling) pada hopper. Cocok untuk membuat : Kuotie Ayam, Jiaozi, Dimsum, Gyoza. Mesin berukuran portable ini bekerja secara semi otomatis dengan kapasitas produksi hingga 1500 pcs tiap jam.



Simple Operation



DR-JZ1D



Skin Ø	Skin Weight	Filling Weight	Weight
75mm	7gr	11gr	18gr

Gyoza skin standard size

**) Berat pada tabel adalah ilustrasi, berat sesungguhnya tergantung pada adonan*

Features

- Material : Stainless steel, aluminium alloy
- Conveyor belt
- Operation button
- Knob ON/OFF & Light indicator
- Hopper height 22cm

Gyoza optional size (*)

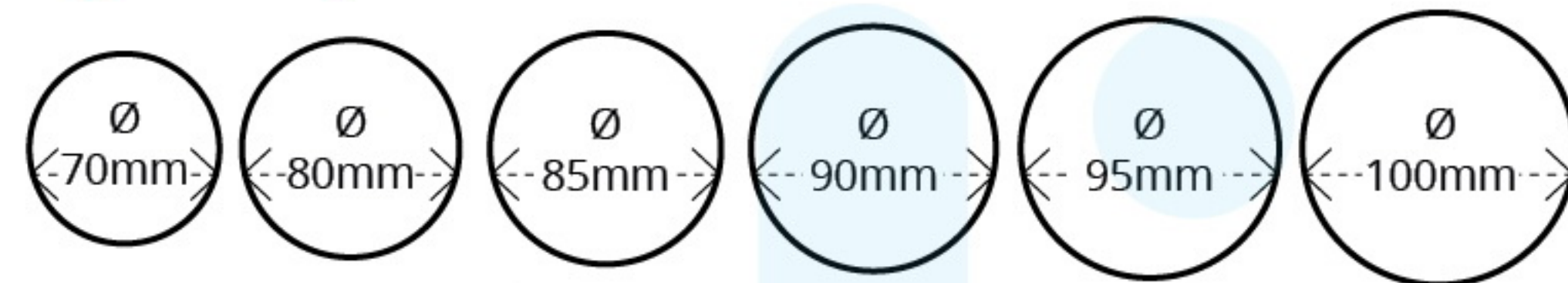

Skin Ø	Skin Weight	Filling Weight	Weight
70mm	6gr	9gr	15gr
80mm	8gr	12gr	20gr
85mm	9gr	13gr	22gr
90mm	9/10gr	14gr	24gr
95mm	13gr	17gr	30gr
100mm	11gr	22gr	33gr

() Untuk pemesanan unit dengan ukuran optional dapat dilakukan indent (1 ukuran untuk setiap mesin)*

TYPE	DIMENSION (cm)			HOPPER HEIGHT (cm)	CAPACITY (pcs/hour)	POWER (Watt)	VOLTAGE	WEIGHT (kg)
	L	W	H					
DR-JZ1D	35	37	48	22	1500	900	220V/1P/50Hz	45

Note:

- Resep adonan kemungkinan harus disesuaikan (adjustment) apabila sebelumnya proses pembuatan dilakukan secara manual.

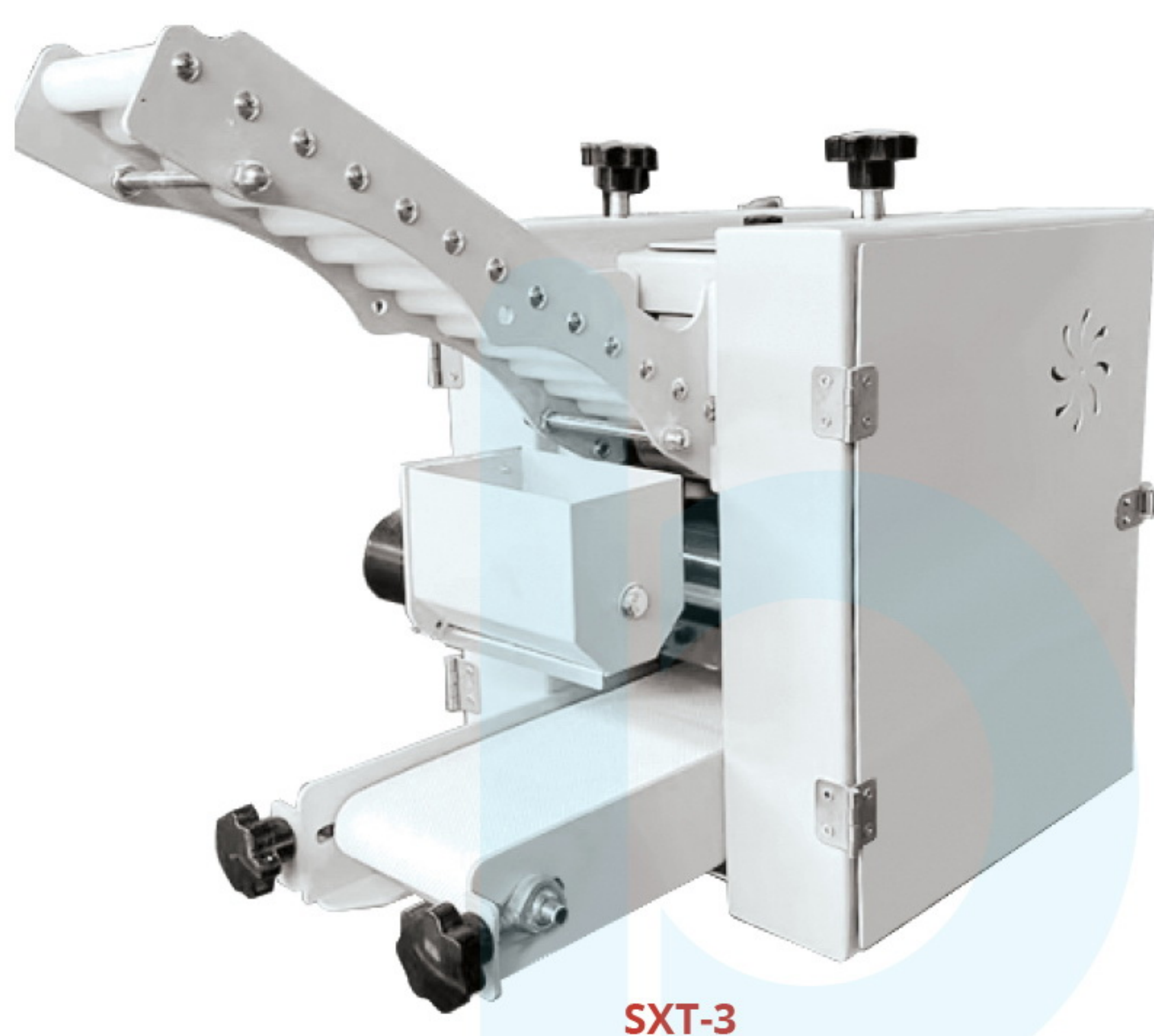

SXT-3

Mesin untuk membuat kulit dumpling (gyoza) secara otomatis, memproses adonan dumpling menjadi kulit dengan diameter bisa diatur (ukuran standar 8cm). Mampu memproduksi kulit dumpling 60 pcs/menit

Features

- Dumpling skin size can be customized, the regular size is 80mm
- Adjusting handle/knob
- Powder bucket



TYPE	DIMENSION (cm)			CAPACITY (pcs/min)	POWER (Watt)	VOLTAGE	WEIGHT (NW/GW) (kg)
	L	W	H				
SXT-3	52	32	47	60	2500	220V/1P/50Hz	60 / 65

Noodle Maker

GETRA[®]

bali
coolers
www.balicoolers.com



Portable Noodle Maker

Features

- ABS Cover
- Stainless Steel for structure / mold, roller
- Portable
- Dough width 18 cm, Diameter: 6.5 cm
- Low noise
- Belt drive
- Rocker Handle Adjusters (one mold has 2 sizes)
- Can choose 2/6 noodle size (standard 2 mm or 6 mm) and 3/9 (optional 3 mm or 9 mm)



DHH-180C



Free Standing Noodle Maker



DZM-300

Lebar Adonan: 22 cm



DZM-350

Lebar Adonan: 30 cm

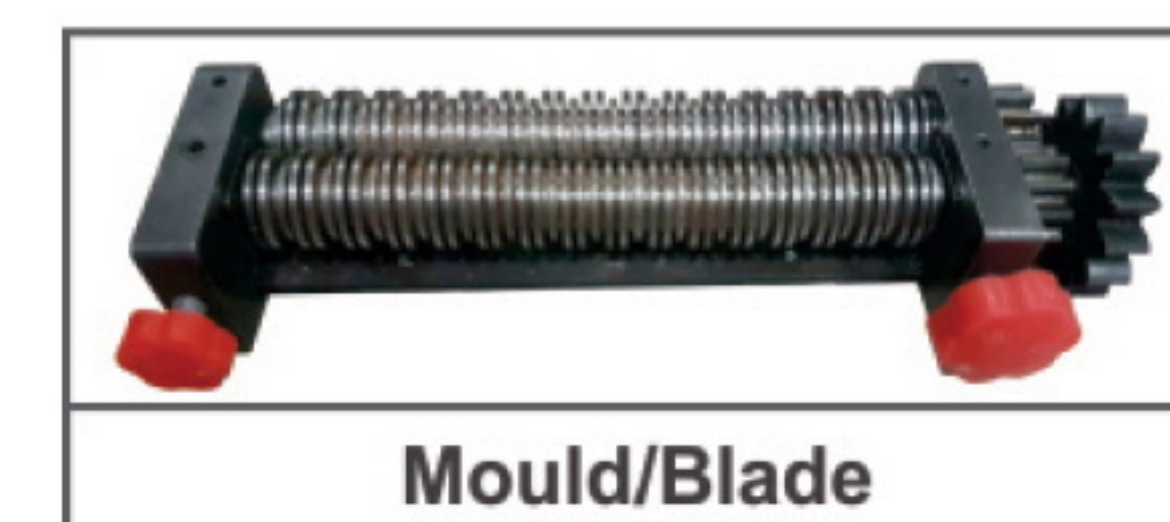

Mould/Blade

Features

- ABS Cover
- Stainless Steel for structure / mold, roller
- Low noise
- Belt drive
- One mold there are 2 kinds of sizes Can choose the size of noodles 2/6 (standard 2 mm / 6 mm) and 3/9 (optional 3 mm or 9 mm)

TYPE	DIMENSION (cm)			ROLLER (cm)	PRODUCTION CAP. (kg/hour)	WATT (220V/1P)	SPEED (rpm)	NW/GW (kg)	OPTIONAL (Blade/ Mould)
	L	W	H						
DHH-180C	37,5	32,5	40	18	0,5 ~ 1	370 W	37	16.7/17,7	800.000
DZM-300	46,5	39,5	91,5	23	30 ~ 35	750 W	50	68 / 75	910.000
DZM-350	54,5	39,5	91,5	31	35 ~ 40	1500 W	50	81 / 90	990.000

www.balicoolers.com

Cake Decorating Machine



DM-1

Mesin untuk menghias / mendekor cake, memoles cream, sangat mudah dioperasikan. Cocok untuk bakery shop, cake shop, ice cream shop, membuat kue tar ulang tahun, dll.

Features

- High efficiency & time saving
- Easy operation, easy to clean
- Knob controller
- Power switch

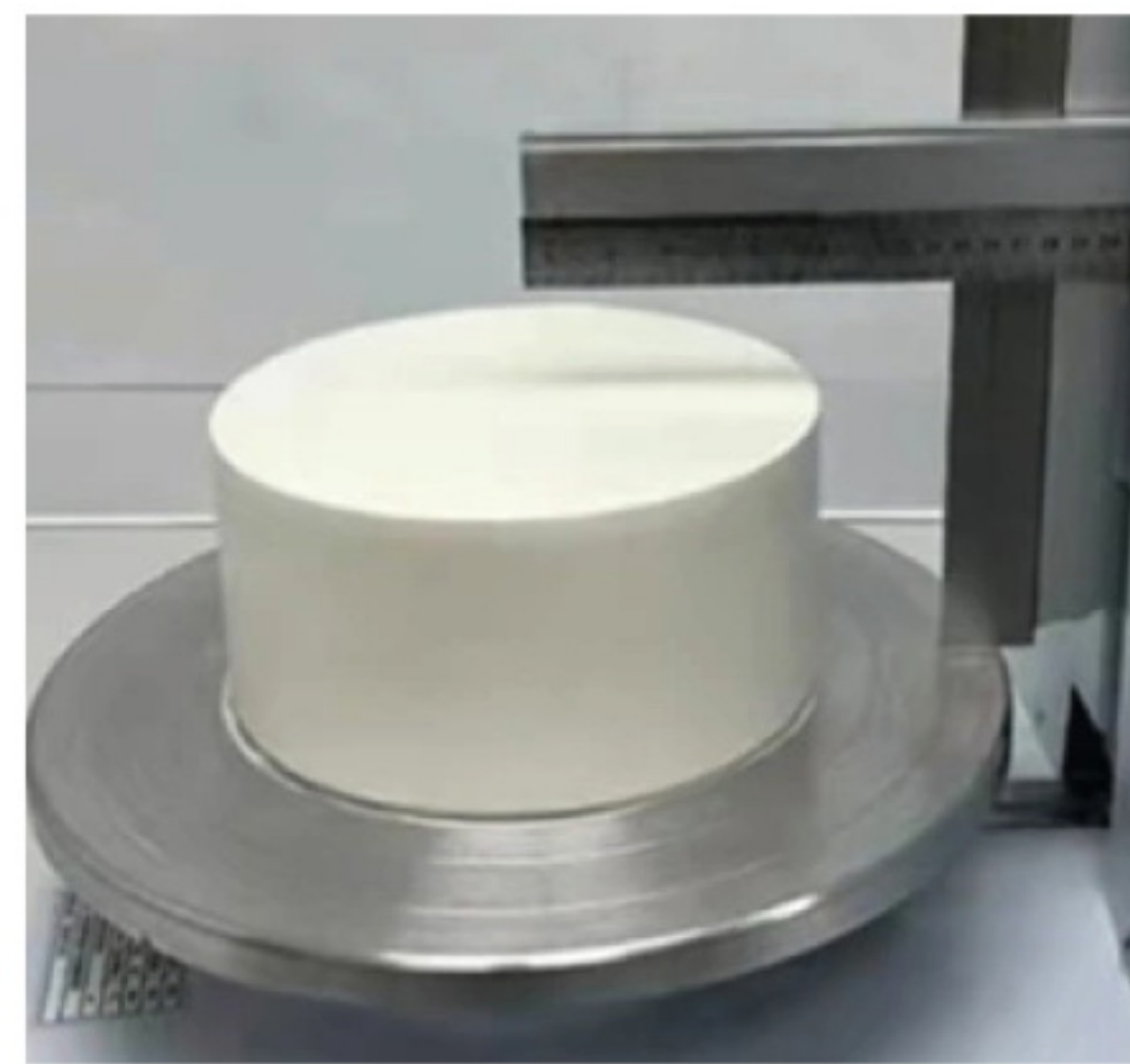

TYPE	DIMENSION (cm)			CAKE DIMENSION		WATT	VOLTAGE	SPEED (r/min)	WEIGHT (kg) Nett Gross
	L	W	H	Ø (mm)	Height (mm)				
DM-1	51	35	48	100~ 300	130	60	220V/1P/50Hz	0~150	26 / 28

Alumunium Pan

Ketebalan : 1,2mm



AP-6430

Perforated



AP-6430P

Teflon, Ketebalan : 1,4mm
Aluminium black coated



AP-6430CB

Corrugated

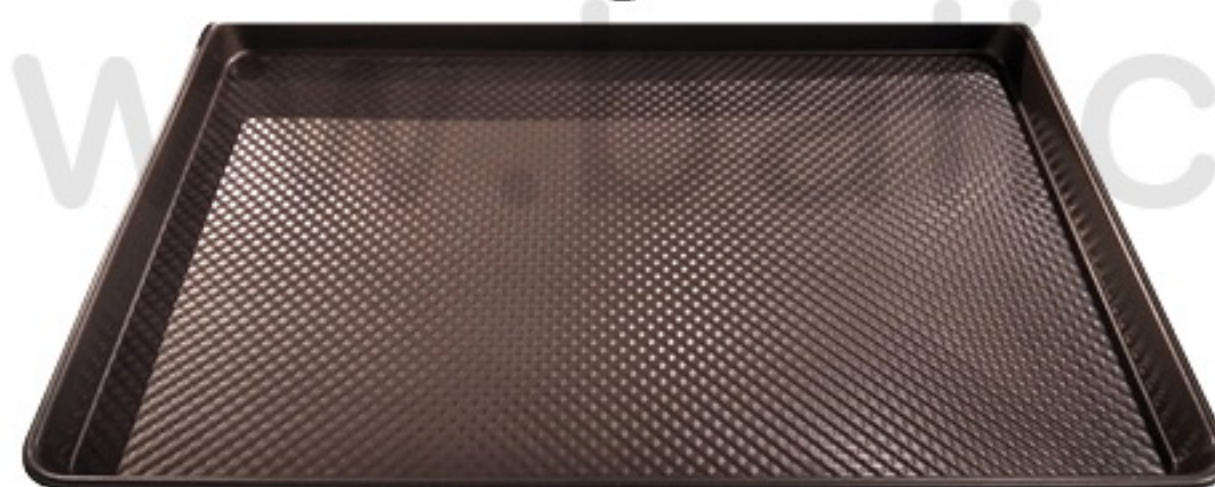

AP-6430COR

TYPE	DIMENSION L x W x H (cm)		
	AP-6430	60	40
AP-6430P	60	40	3

TYPE	DIMENSION L x W x H (cm)		
	AP-6430CB	60	40
AP-6430COR	60	40	3

Loaf Box, Teflon Coated Inside



LP-450

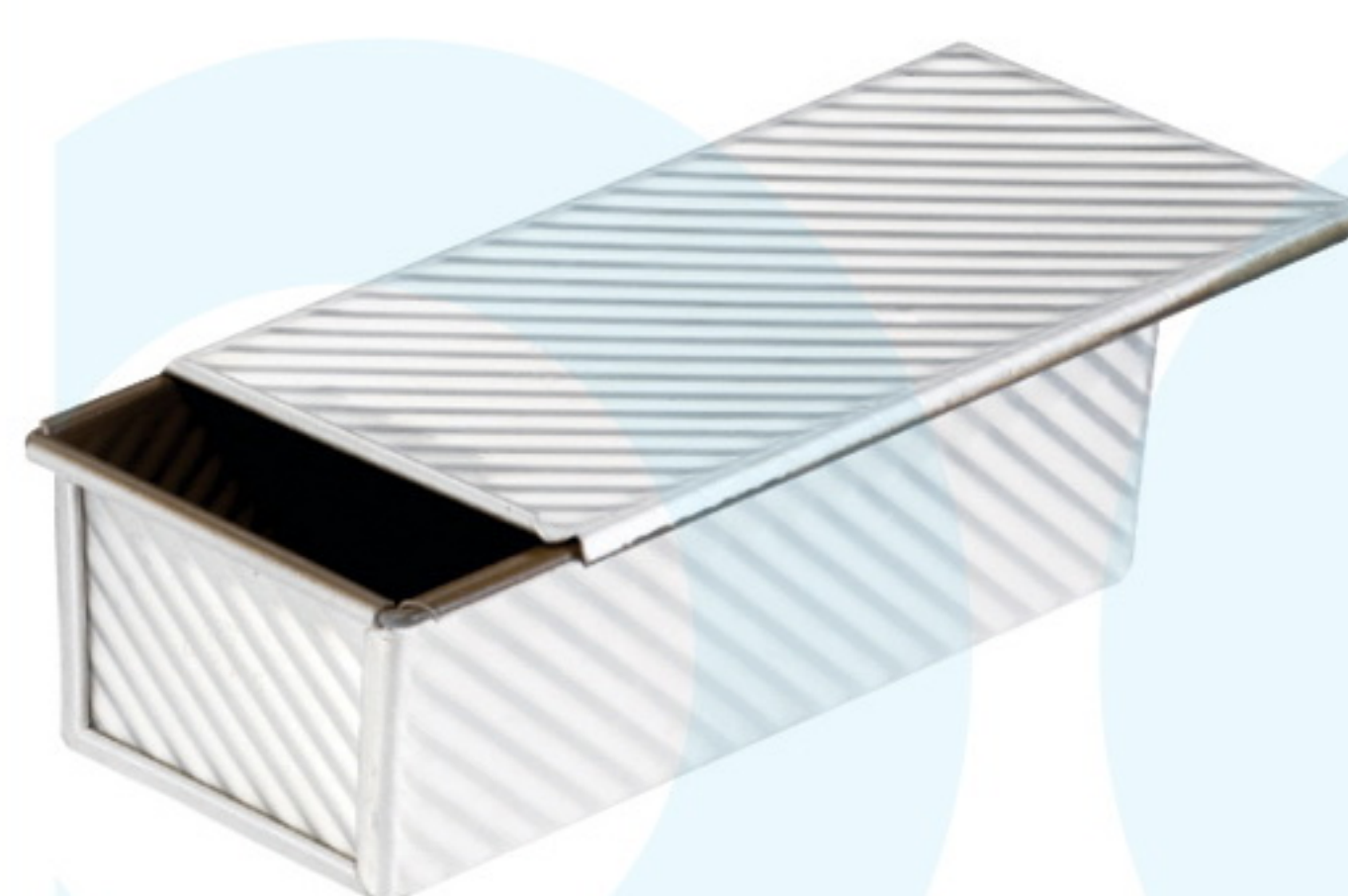

LP-1000

TYPE	DIMENSION L x W x H (cm)		
	LP-450	19,7	10,6
LP-1000	32,7	12,1	12

Stainless Steel Pan



TR-6448



TR-6420P

TYPE	DIMENSION L x W x H (cm)		
	TR-6448	60	40
TR-6420P	60	40	5

GETRA[®]

bali
coolers
www.balicoolers.com

